

### XY Frame Assembly



Created by:  
Joshua Vasquez

last edited:  
6/1/2020

SCALE: 1:3

SHEET 1 OF 17

2

1

This next process aligns the Inside-Corner Brackets to ensure a square frame. Using the temporary short extrusions, slide the top frame onto the completed Lower frame assembly.

B

B

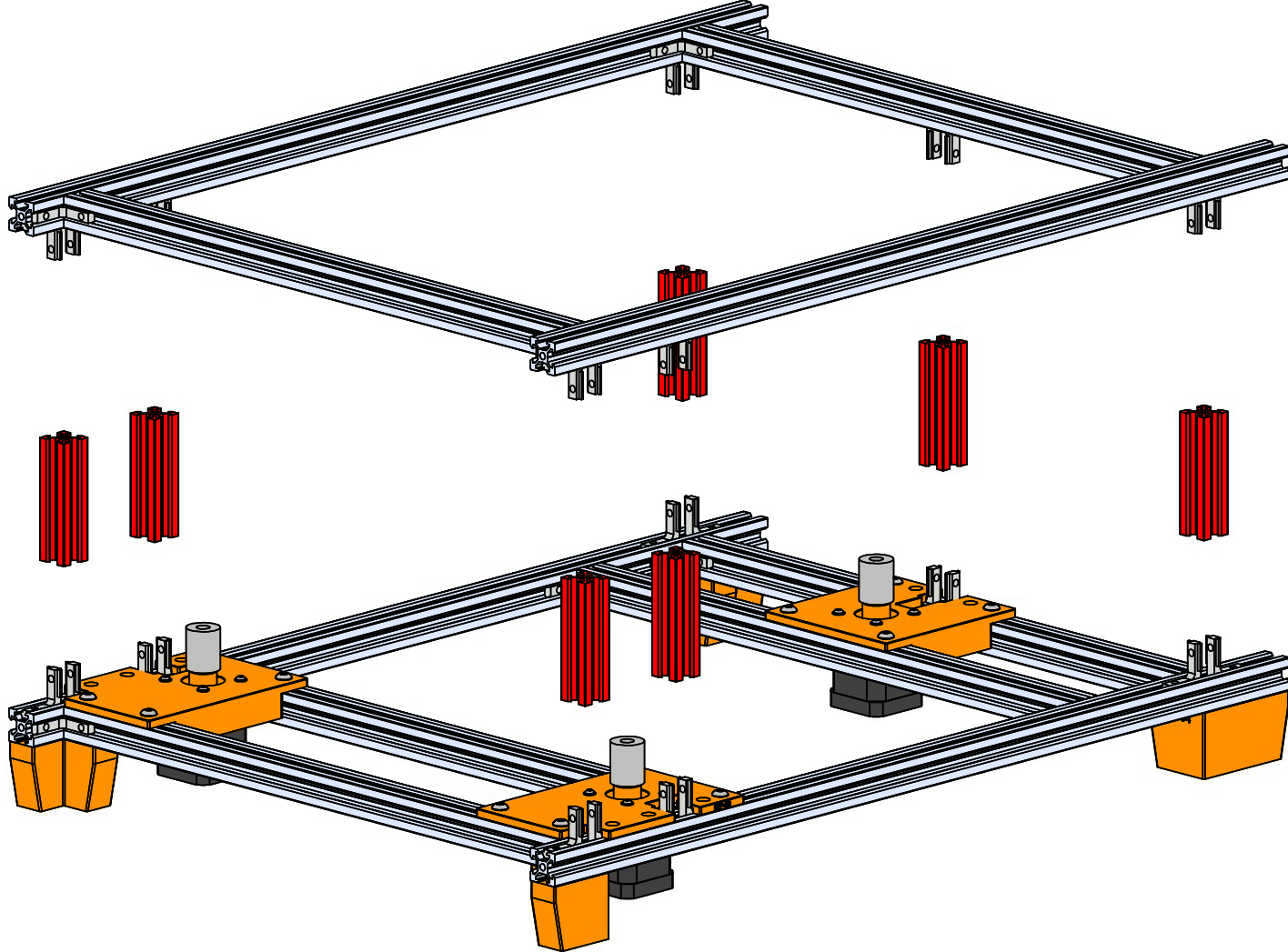

A

A

Tighten all Inside-Corner Brackets on the lower frame first to set their location. Then tighten the screws for all Inside-Corner Brackets attached to the upper frame. With all set screws tightened, the Inside-Corner Bracket positions should be fixed on the upper and lower frames.

Now, loosen all set-screws connecting the red extrusions only to the lower frame.

Set aside the lower frame.

### Upper Bracket Alignment 1



Created by:  
Joshua Vasquez

last edited:  
6/1/2020

SCALE: 1:4

SHEET 2 OF 17

2

1

2

1

For the rest of this instruction booklet, you can work with the frame propped up on the red extrusions. (They will not be shown in the renderings.)

B

B

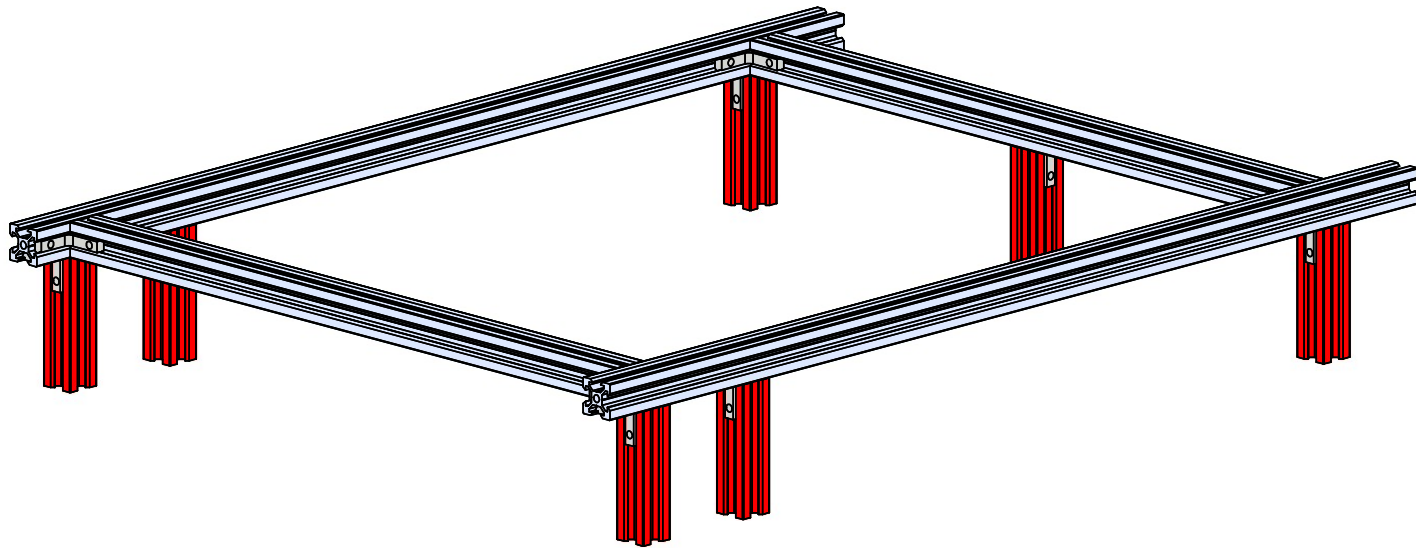

A

A

2

1

### Frame Conveniences



Created by:  
Joshua Vasquez

last edited:  
6/1/2020

SCALE: 1:4

SHEET 3 OF 17

2

1

Securely fasten the center carriage to the crossbar, ensuring that the clearances below are met.

B

B

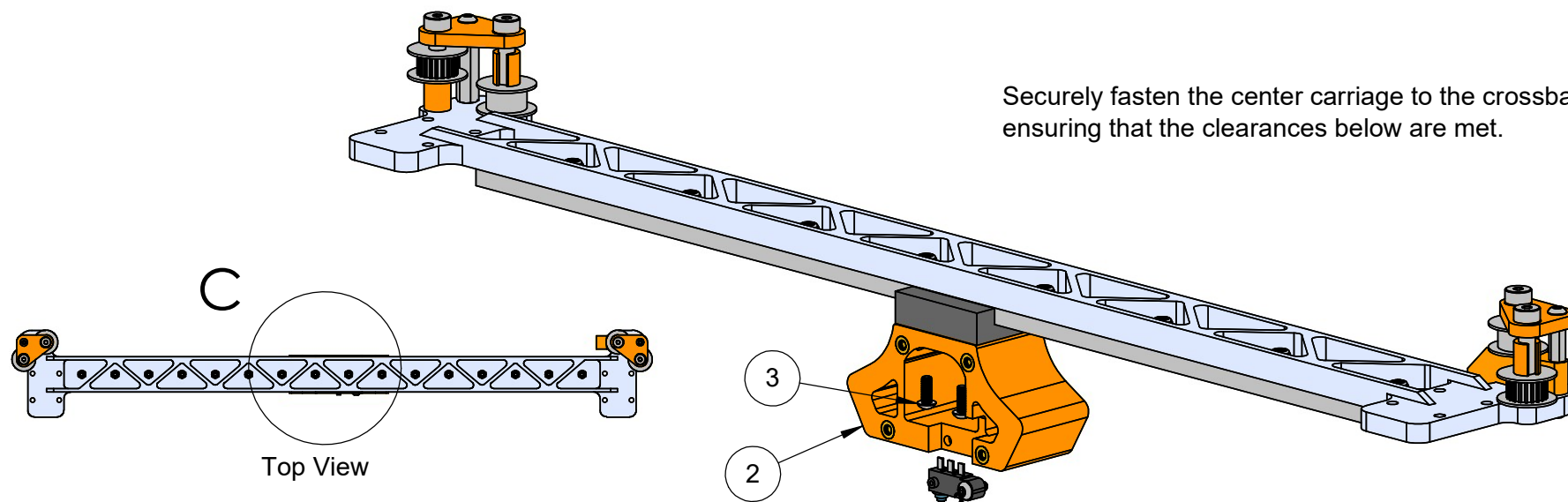

Top View

This limit switch should have wires attached to it (not shown in the rendering above).

Ensure that when the carriage is installed, it clears the crossbar on both sides. Otherwise, the carriage will bind when it slides back-and-forth.

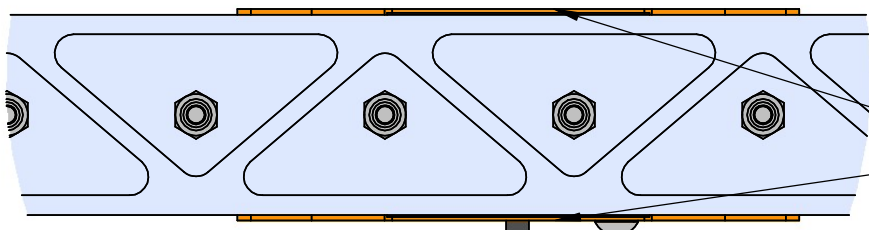

DETAIL C  
SCALE 1 : 1

A

A

ITEM NO.	DESCRIPTION	
1	Crossbar Assembly	1
2	Carriage Center Assembly	1
3	M3 Buttonhead Screw, 8mm long	4

### Carriage Center Installation



Created by:  
Joshua Vasquez

last edited:  
6/1/2020

SCALE: 1:2

SHEET 4 OF 17

2

1

2

1

Make 2 Assemblies.

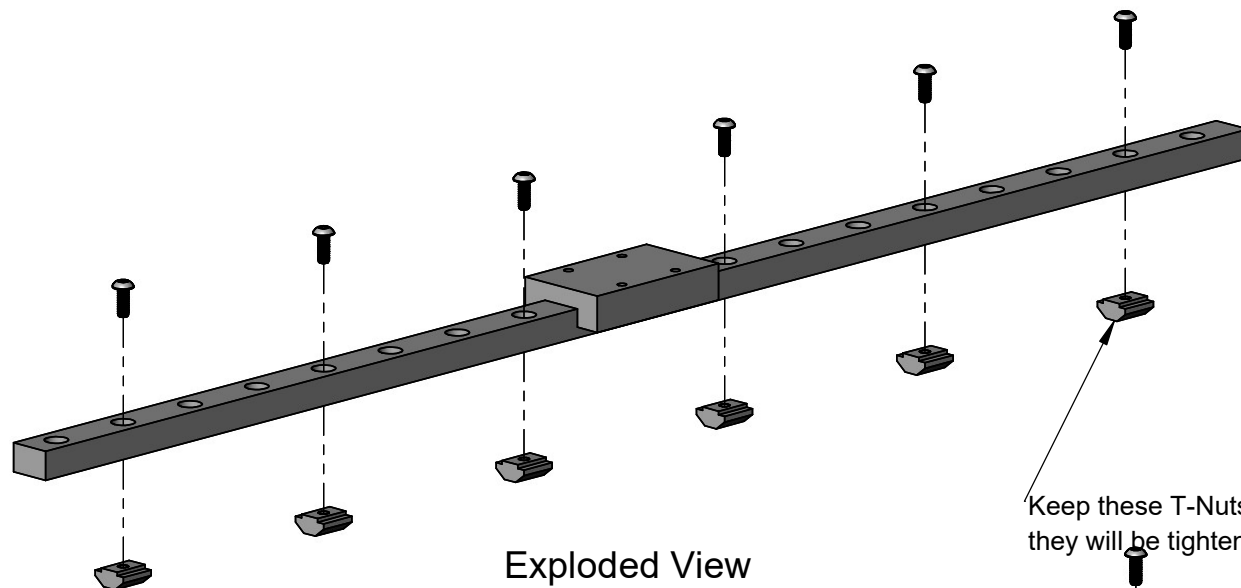

Exploded View

Keep these T-Nuts loose, only 2-3 full turns; they will be tightened into the frame later.

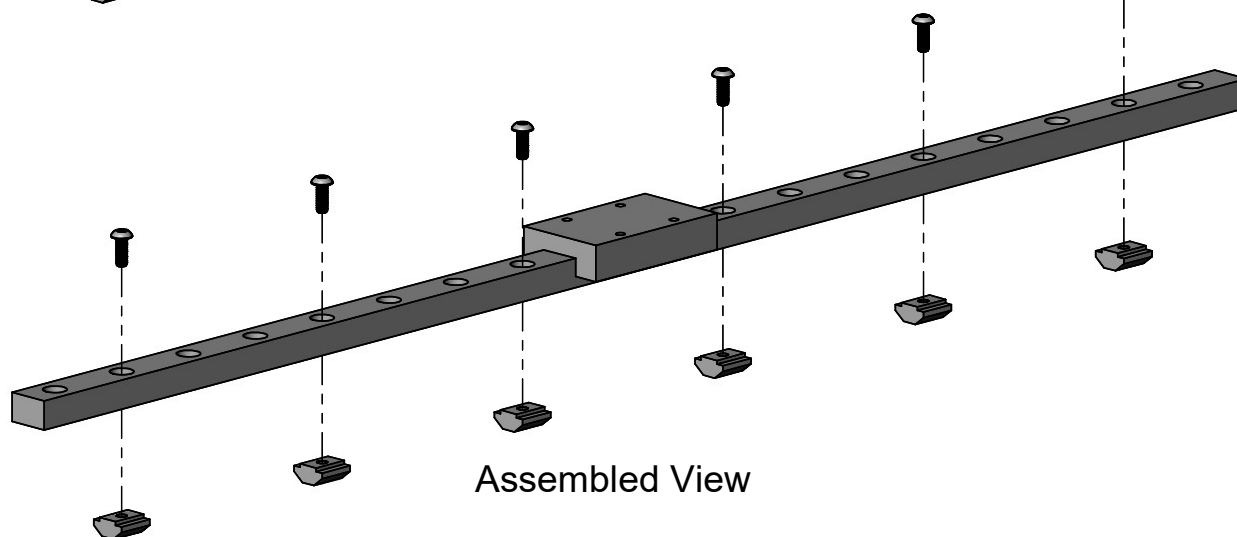

Assembled View

ITEM NO.	DESCRIPTION	QTY.
1	450mm long MGN12 Rail	1
2	MGN12H Carriage Block	1
3	M3 Buttonhead Screw, 8mm long	6
4	M3 Slide In T Nuts	6

## Y Rail Assembly



Created by:  
Joshua Vasquez

last edited:  
6/1/2020

SCALE: 1:2

SHEET 5 OF 17

2

1

B

B

A

A

2

1

Securely screw down all M5 screws.  
Ensure that the drop-in T nuts seat correctly in the rail groove.

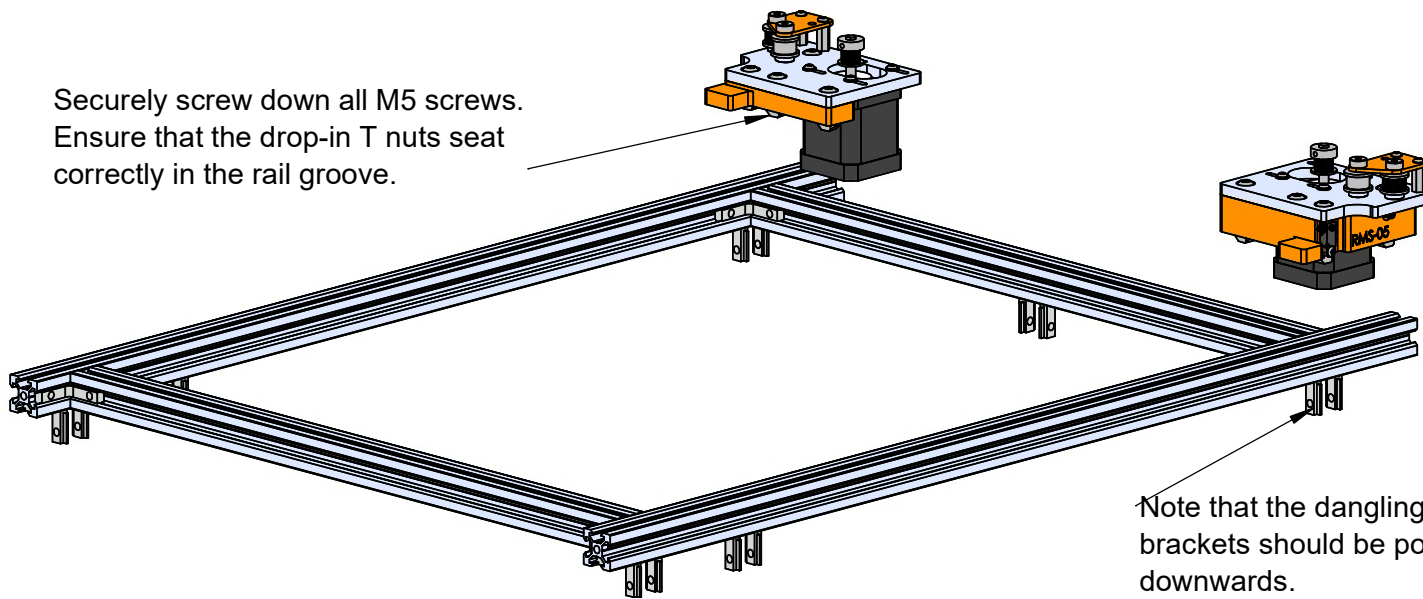

Exploded View

Note that the dangling inside-corner brackets should be pointing downwards.

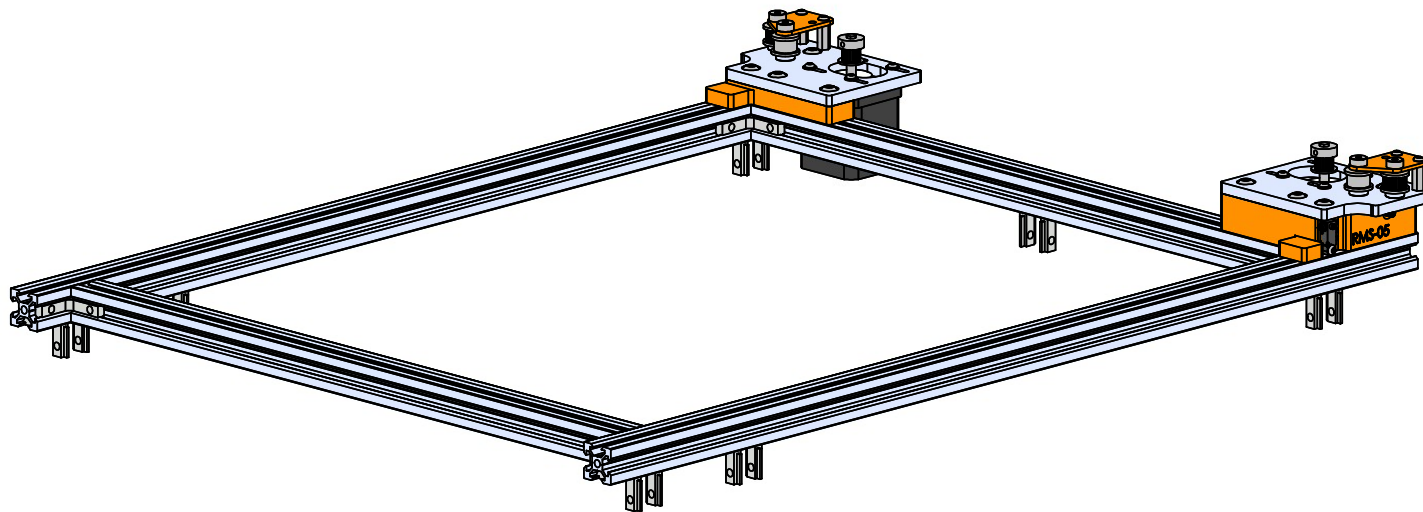

Assembled View

ITEM NO.	DESCRIPTION	QTY.
1	CoreXY Frame Assembly	1
2	Left Motor Plate Assembly	1
3	Right Motor Plate Assembly	1

### Plate Installation 1/2



Created by:  
Joshua Vasquez

last edited:  
6/1/2020

SCALE: 1:4

SHEET 6 OF 17

2

1

B

B

A

A



2

1

B

B

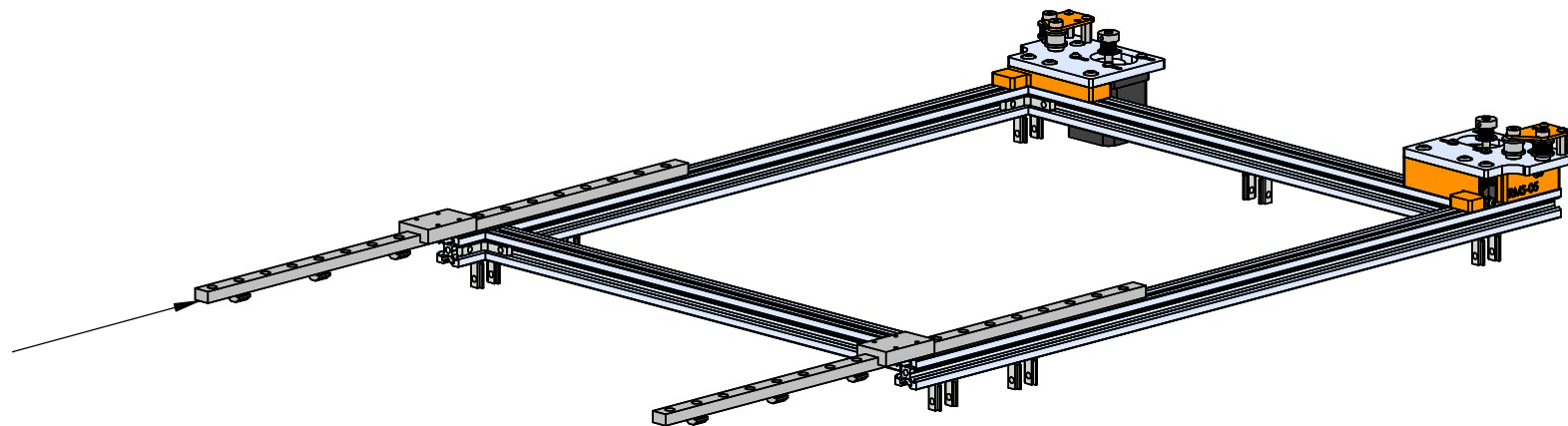

Slide in the Y rails from the front and loosely fasten them to the frame. Don't fully tighten them yet.

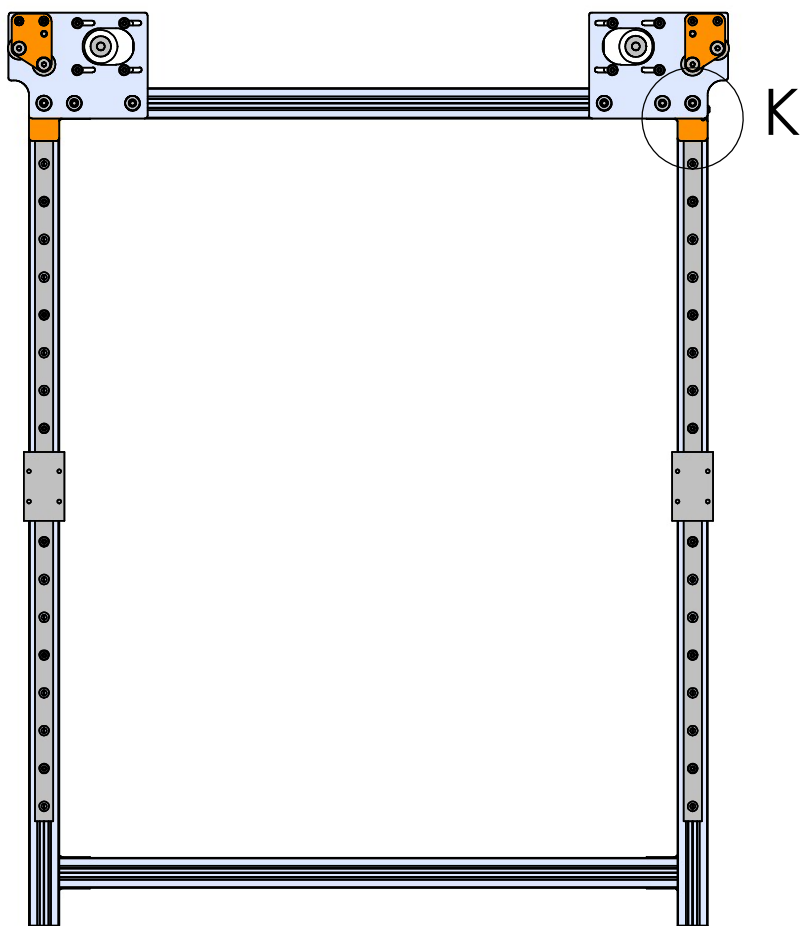

K

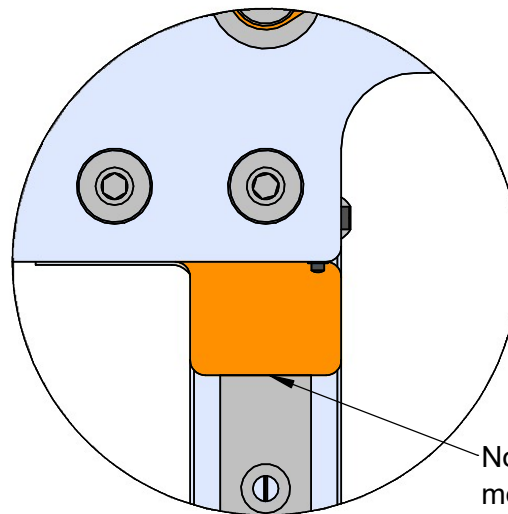

Note that the rails are flush with the motor brackets.

DETAIL K  
SCALE 1 : 1

Y Rail Installation



Created by:  
Joshua Vasquez

last edited:  
6/1/2020

SCALE: 1:5

SHEET 7 OF 17

2

1

A

A

2

1

B

B

Securely screw down all M5 screws.  
Ensure that the drop-in T nuts seat correctly in the rail groove.

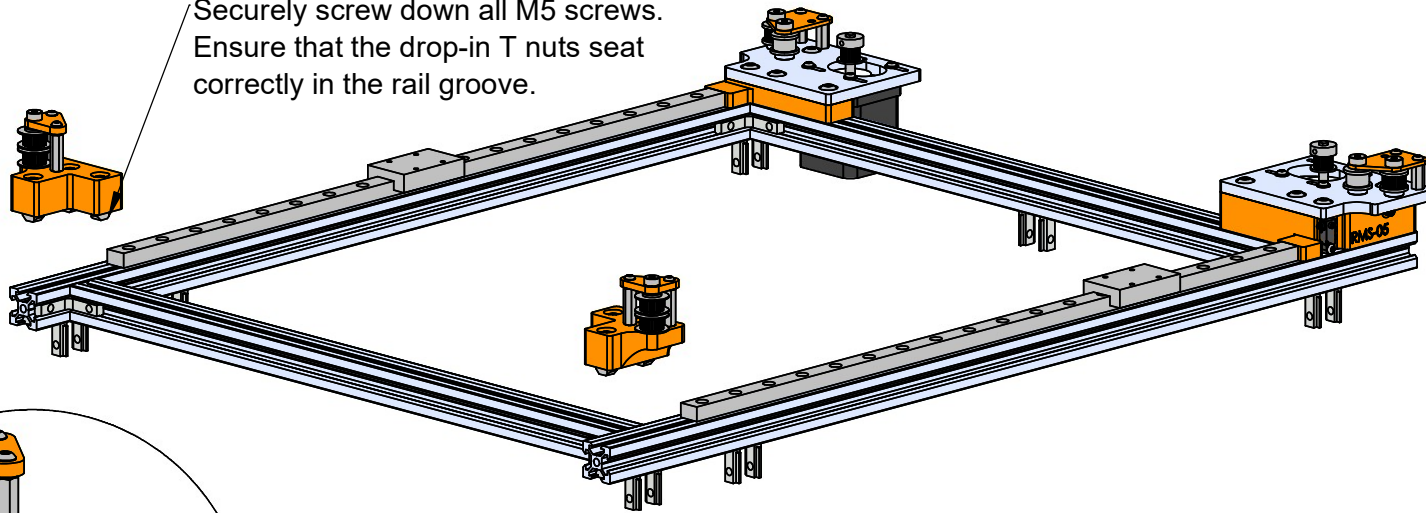

Exploded View

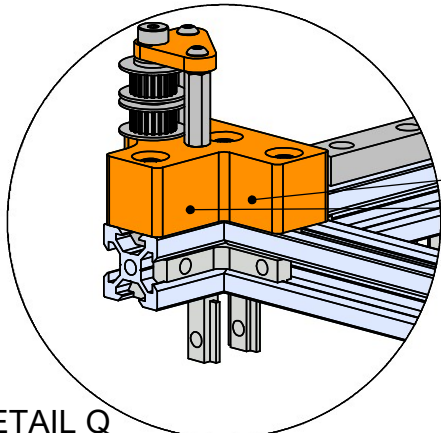

These surfaces will be flush with the extrusions.

DETAIL Q  
SCALE 1 : 2

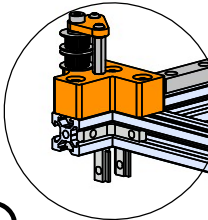

Q

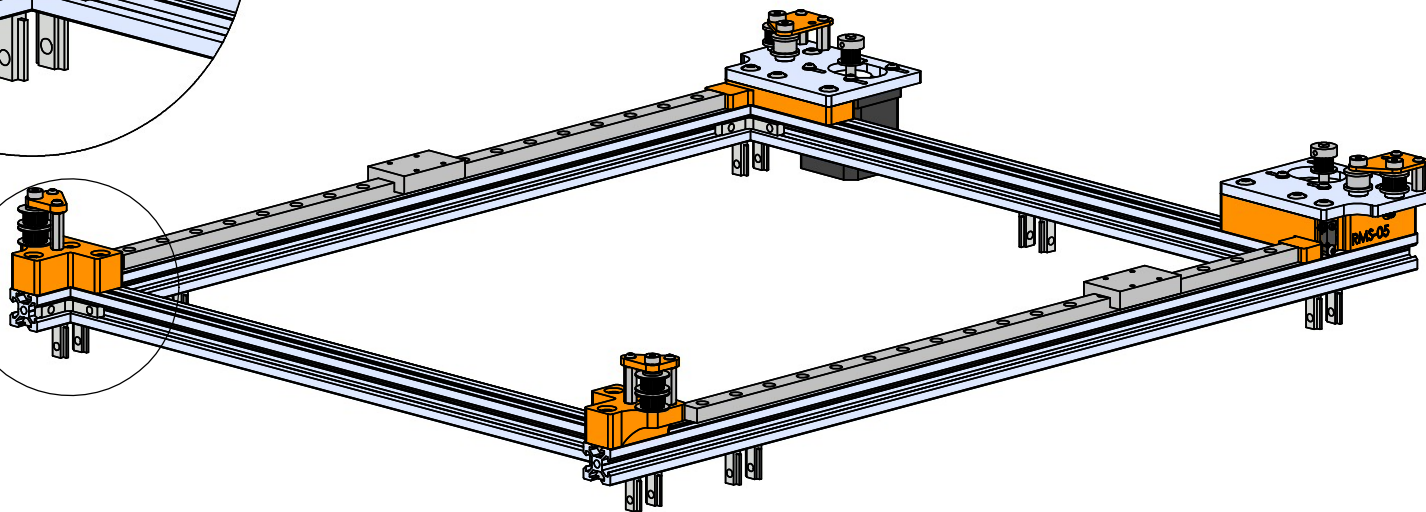

Assembled View

A

A

ITEM NO.	DESCRIPTION	QTY.
1	CoreXY Frame Assembly	1
2	Left Corner Pulley Assembly	1
3	Right Corner Pulley Assembly	1

### Plate Installation 2/2



Created by:  
Joshua Vasquez

last edited:  
6/1/2020

SCALE: 1:4

SHEET 8 OF 17

2

1



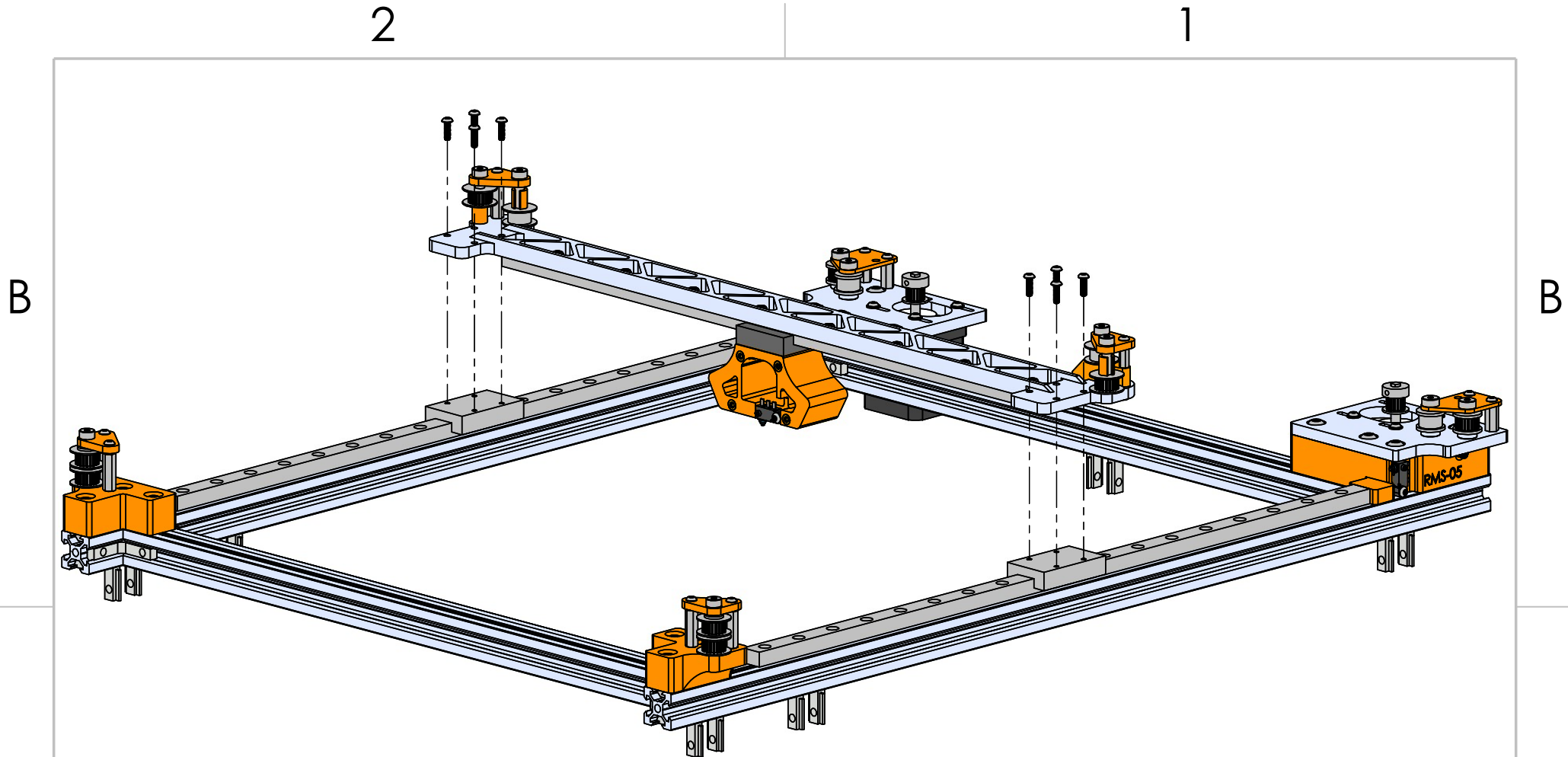

Install the Crossbar in the orientation shown above. Secure it with fasteners snugly, but do not fully tighten it.

ITEM NO.	DESCRIPTION	QTY.
1	CoreXY Frame Assembly with Y Rails	1
5	M3 Buttonhead Screw, 10mm long	8
6	Crossbar Assembly with Carriage Center	1

Crossbar Installation		
	Created by: Joshua Vasquez	last edited: 6/1/2020
	SCALE: 1:3	SHEET 9 OF 17

2

1

B

B

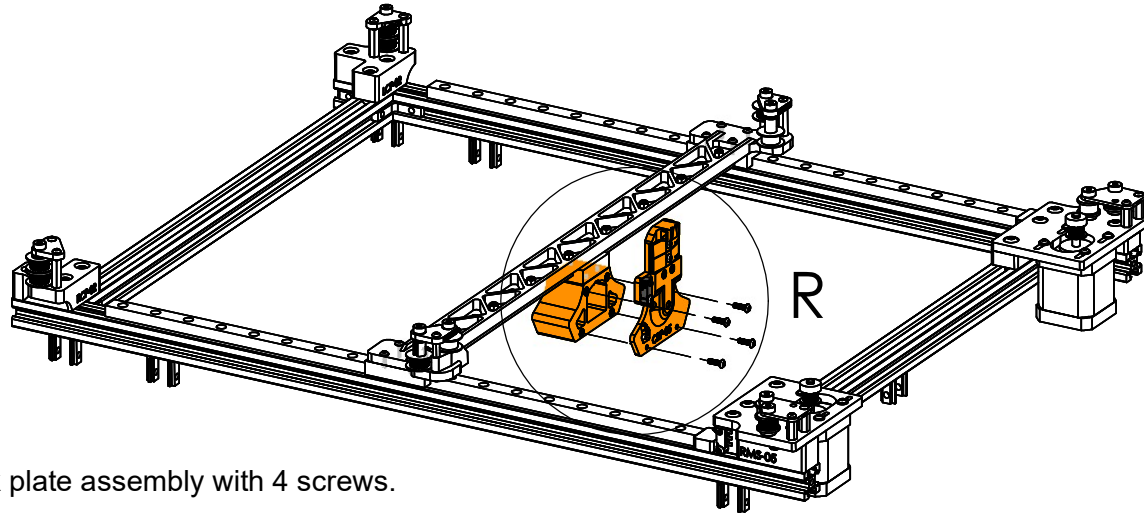

Install the carriage back plate assembly with 4 screws.

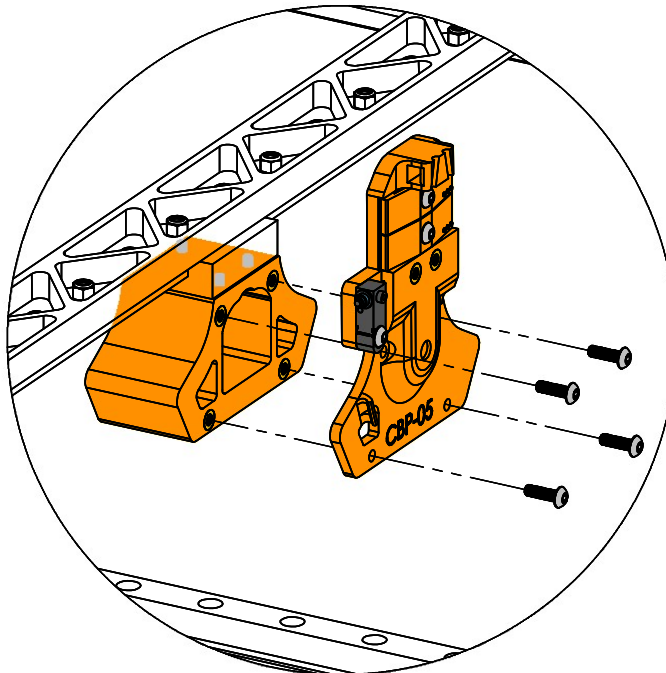

DETAIL R  
SCALE 1 : 2

A

A

ITEM NO.	DESCRIPTION	QTY.
1	CoreXY Frame with Carriage Center Assembly	1
5	M3 Buttonhead Screw, 10mm long	4
7	Carriage Back Plate Assembly	1

<b>Carriage Back Installation</b>		
	Created by:	last edited:
	Joshua Vasquez	6/1/2020
	SCALE: 1:5	SHEET 10 OF 17

2

1

2

1

B

B

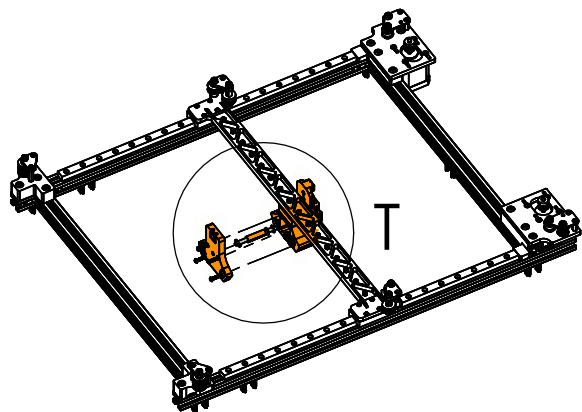

DETAIL T  
SCALE 1 : 2

Note there should be two shim here from the previous step.

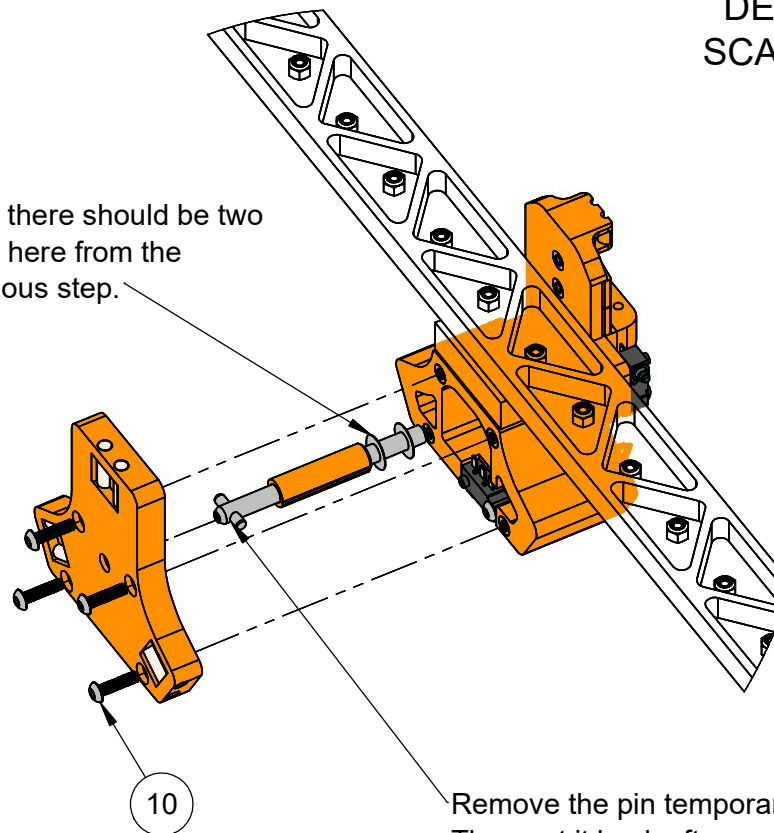

Remove the pin temporarily.  
Then put it back after  
finishing this step.

A

A

ITEM NO.	DESCRIPTION	QTY.
7	Toolchanger Twist-Lock Assembly	1
8	Toolchanger Coupling Plate Assembly	1
10	M3 Buttonhead Screw, 12mm long	4
12	Toolchanger Pulley Assembly	1
15	Spring Guide Capture	1

### Front Carriage Assembly



Created by:  
Joshua Vasquez

last edited:  
6/1/2020

SCALE: 1:10

SHEET 11 OF 17

2

1

2

1

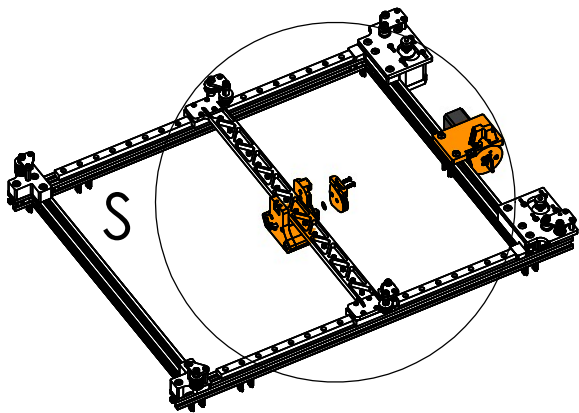

First screw in the Remote Elastic Lock (16) in the back of the frame.

Then screw in the Spring Guide Capture (15) into the back of the carriage, ensuring that the Spring Guide is not twisted. Note that the actual spring guides are not shown in the render.

Finally, push the Carriage Pulley (12) into the back of the twist lock. Do not tighten it yet.

Note: Spring Guide isn't shown in the rendering on the right, but your real machine should have it!

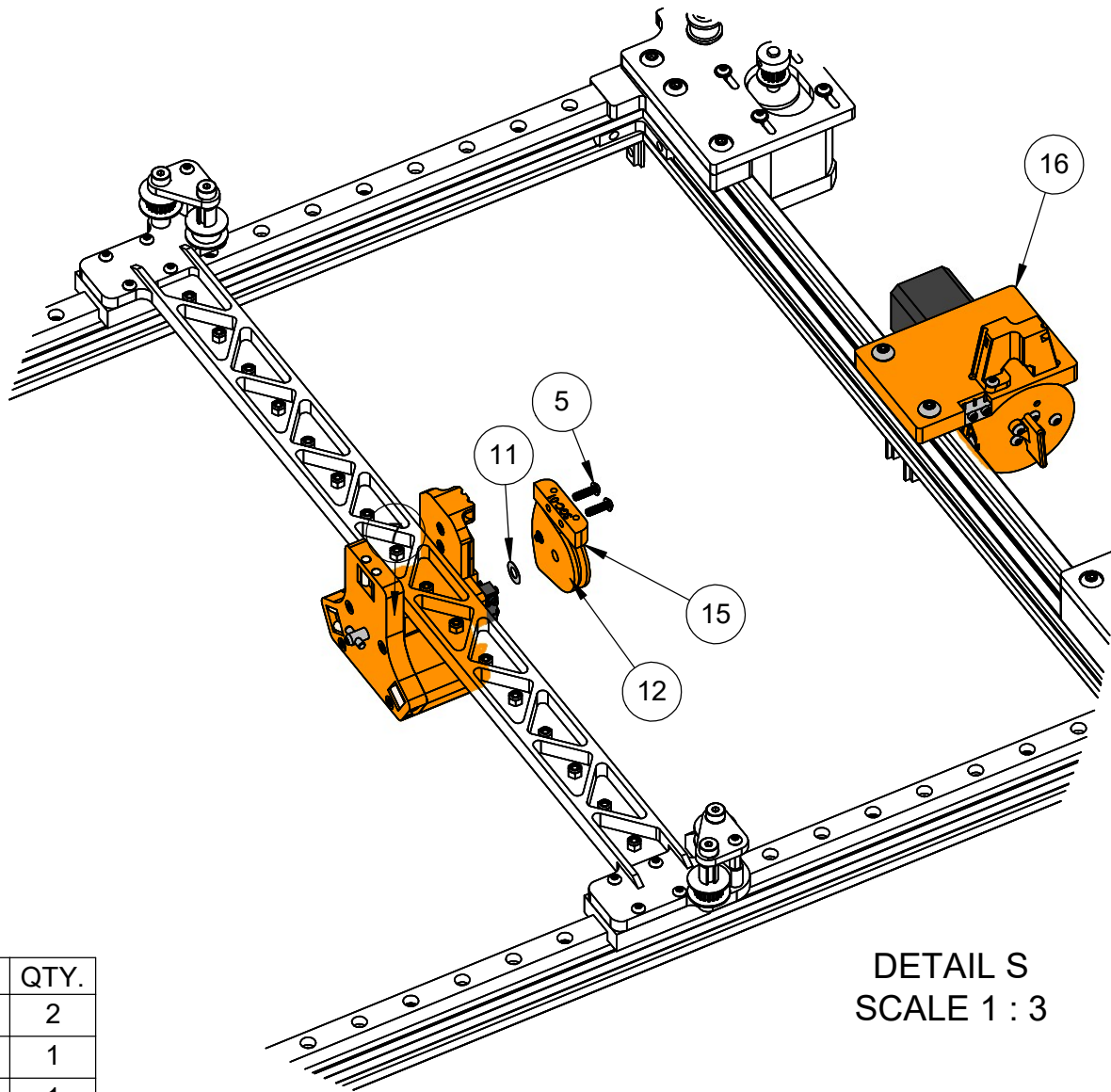

DETAIL S  
SCALE 1 : 3

ITEM NO.	DESCRIPTION	QTY.
5	M3 Buttonhead Screw, 10mm long	2
7	Toolchanger Twist-Lock Assembly	1
8	Toolchanger Coupling Plate Assembly	1
10	M3 Buttonhead Screw, 12mm long	4
11	M5 Shim, 0.2mm thick, 10mm OD	1
12	Toolchanger Pulley Assembly	1
15	Spring Guide Capture	1
16	Remote Elastic Lock	1

### Remote Elastic Lock Installation



Created by:  
Joshua Vasquez

last edited:  
6/1/2020

SCALE: 1:10

SHEET 12 OF 17

2

1

2

1

B

B

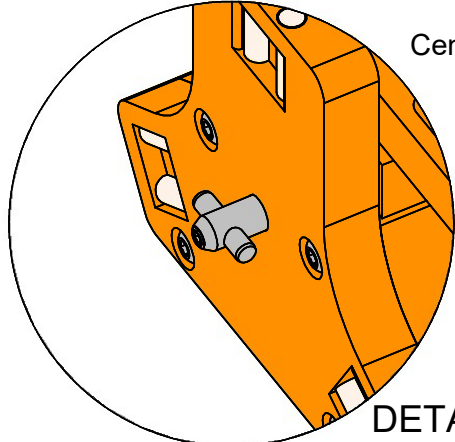
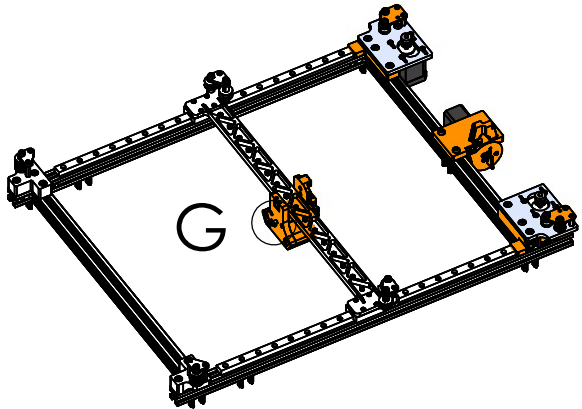

Center the 3mm dowel pin and tighten it with the setscrew.

DETAIL G  
SCALE 1 : 1

A

A

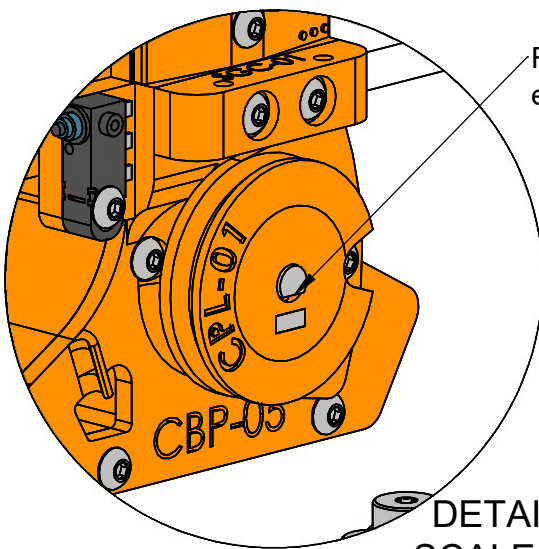
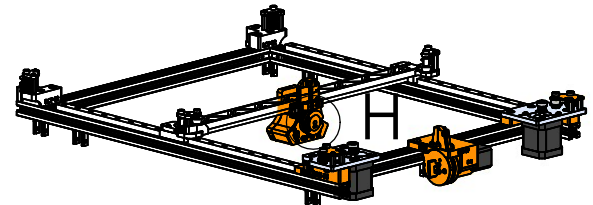

Fasten down the pulley setscrew ensuring that it engages the flat part of the twist-lock shaft.

DETAIL H  
SCALE 1 : 1

Twist Lock Orientation Check		
	Created by:	last edited:
	Joshua Vasquez	6/1/2020
	SCALE: 1:10	SHEET 13 OF 17

2

1



B

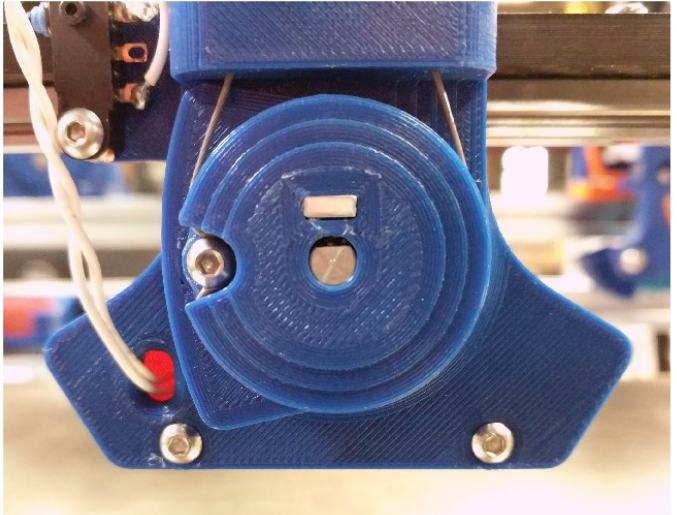

Hold the carriage-side pulley in this configuration.

By hand, manually twist the pulley on the carriage until it is in the fully unlocked position as shown on the left.

Put one hand on the pulley to hold it in this position and prevent it from rotating.

With one hand on the carriage-side pulley, rotate the lock actuator pulley until it clicks the external switch (lower left image). In this process, one wire rope should slip while the other one should stay under tension. Now let go of the carriage side pulley. Return the fixed pulley to a neutral position and tighten its cinching screw in this position. Then take in the slack on the floating pulley and tighten it too.

The result is that the rotating the twist lock knob back and forth should rotate the carriage pulley without any noticeable backlash. (i.e: the carriage pulley should move when the knob moves.)

B

A

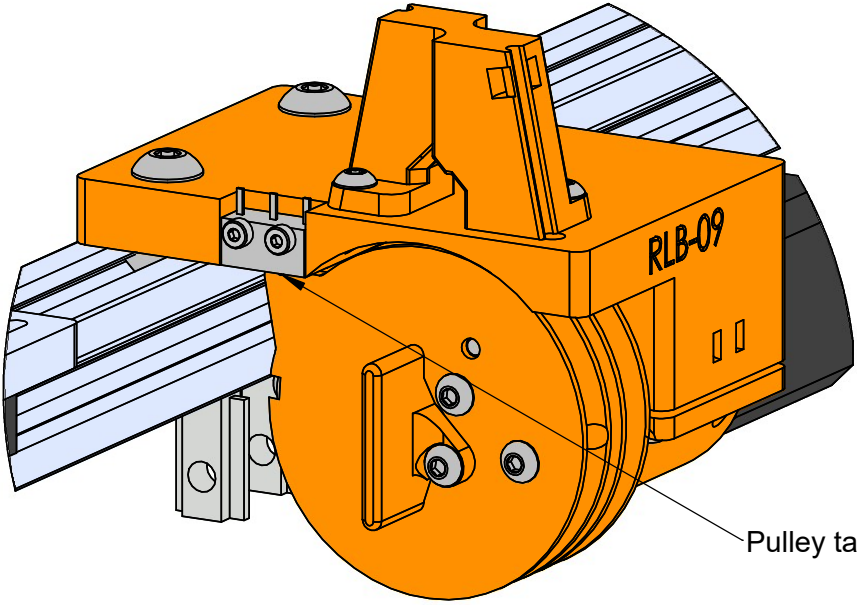

Pulley tab should touch the switch.

Put the Fixed Pulley in this configuration.

A

Lock Actuator Tension Check		
	Created by: Joshua Vasquez	last edited: 6/1/2020
	SCALE: 1:10	SHEET 14 OF 17



2

1

Do this part on a table or other flat surface.

With two 1-2-3 blocks, align the loose x-rail with the carriages on the y-rails by pushing both blocks into the corners ensuring that both contacting faces of all parts are fully flush to the 1-2-3 blocks. Gently apply clamps to hold the blocks in this position. Fully-tighten all remaining loose screws in this configuration. When done, remove the blocks.

B

B

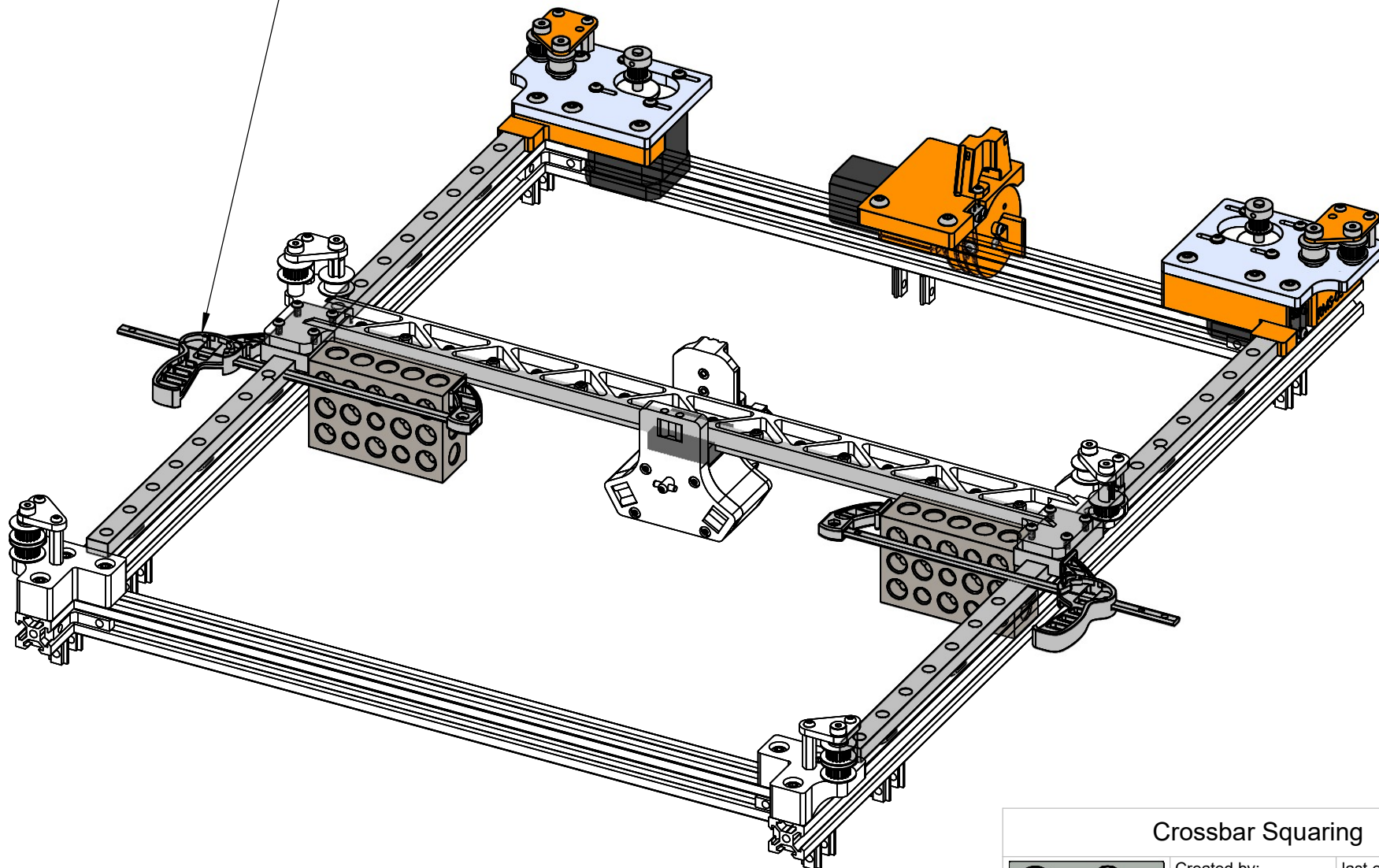

A

A

### Crossbar Squaring



Created by:  
Joshua Vasquez

last edited:  
6/1/2020

SCALE: 1:3

SHEET 15 OF 17

2

1

2

1

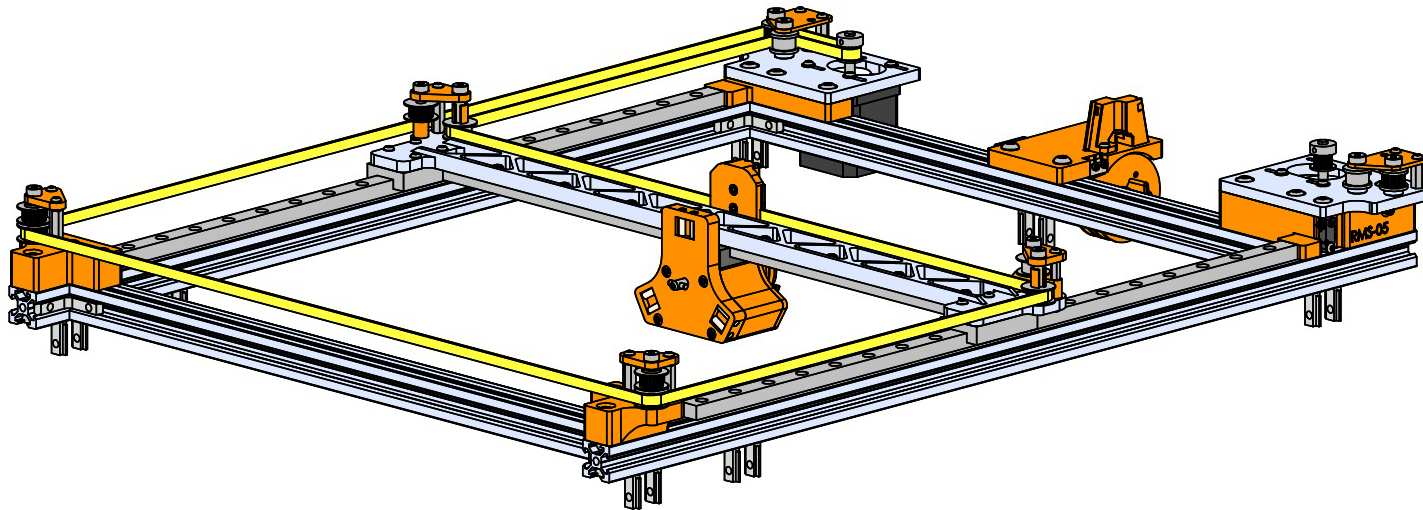

B

B

Install the lower belt by following the pattern shown above and tightening both ends into the carriage. Only 4-5 timing belt teeth need to seat into the carriage, and the belt will feel extremely loose in this configuration. Then do the same for the upper belt pattern shown below.

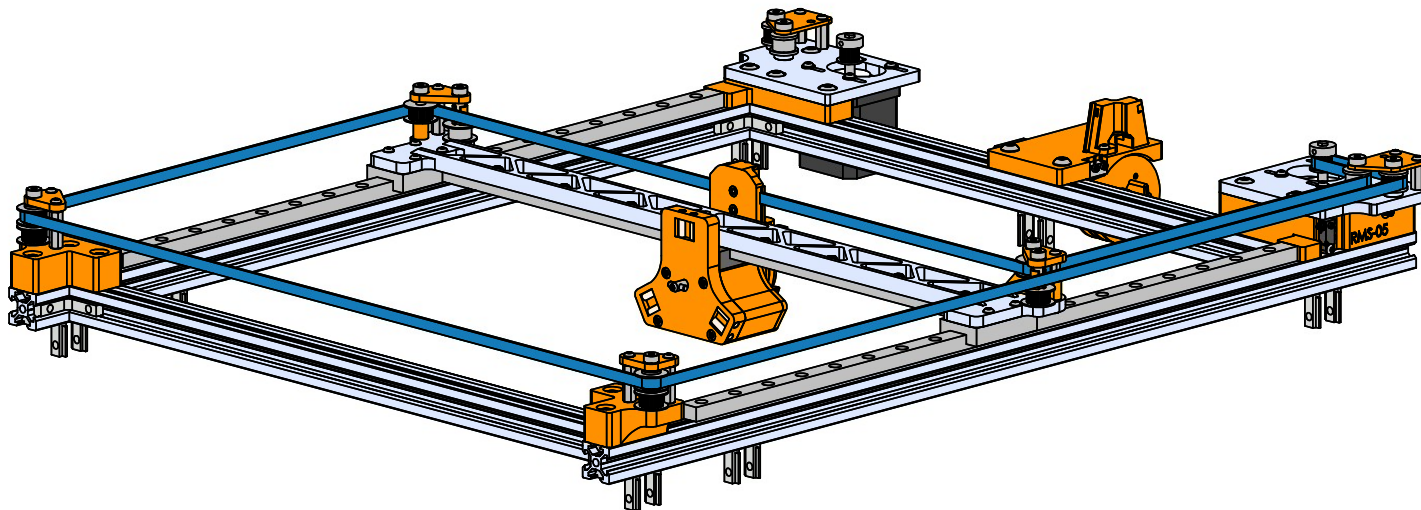

A

A

ITEM NO.	DESCRIPTION	QTY.
1	CoreXY Frame	1
2	2GT Timing Belt, 6mm wide, 2300mm long	2

### Belt Installation



Created by:  
Joshua Vasquez

last edited:  
6/1/2020

SCALE: 1:4

SHEET 16 OF 17

2

1

First center the carriage in the middle of the frame by eye. Belts may skip; that's ok while they're loose. Next, ensure that both drive motors are loose and can slide back-and-forth in their slots when pushed by-hand. Then locate the tensioning setscrews on each sides of the motor corner plates.

B

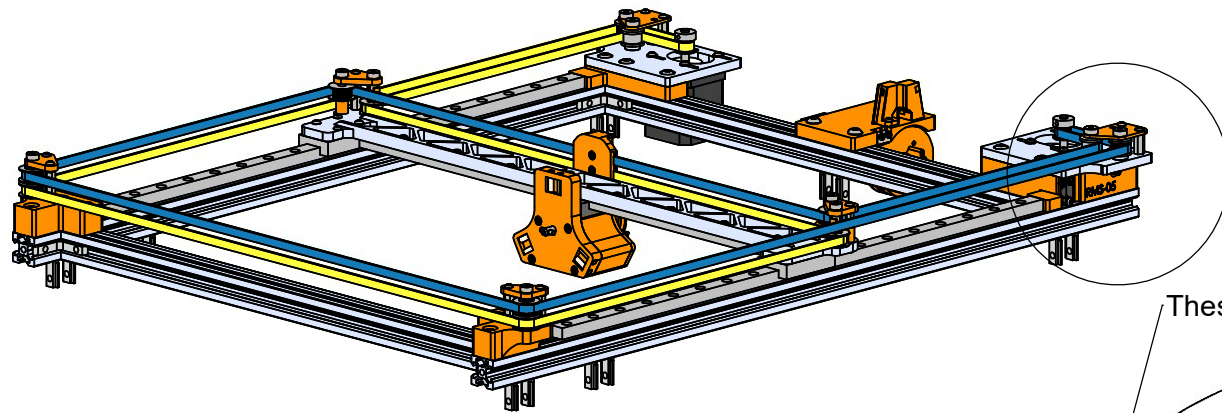

J

B

These motor screws should be loose.

Belt Tensioning Setscrew

DETAIL J  
SCALE 2 : 3

Do this process in a quiet environment.

Install the Gates Carbon Drive App to a smartphone. With the app running and the microphone near the front span of belt, *pluck* the upper belt like a guitar string and measure the frequency. Gradually increase belt tension by tightening the setscrew. When the measurements average between 47 and 53Hz, stop, and tighten the other belt until it matches the first belt frequency within 1Hz. When done, tighten down all 8 XY motor screws.

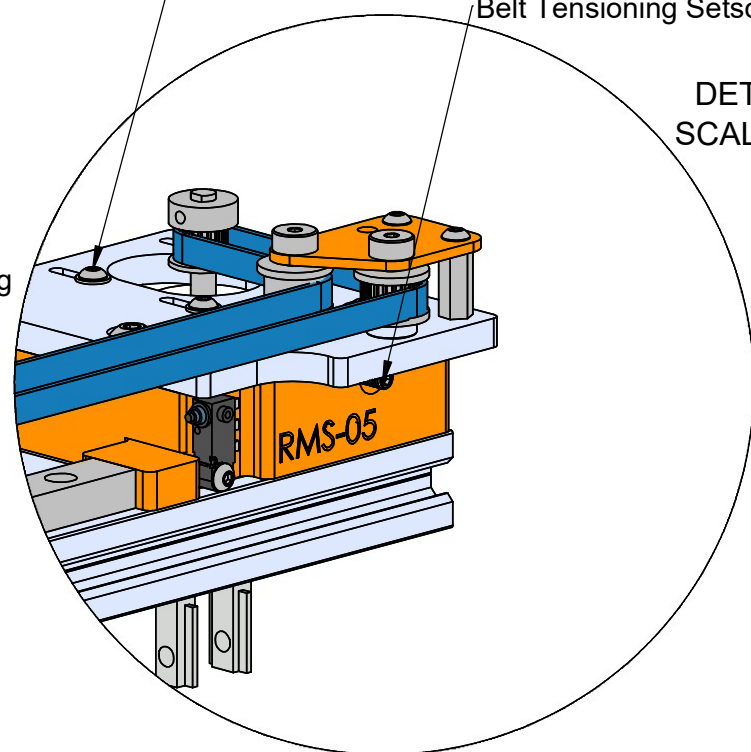

A

A

Your XY Frame is complete! Remove the short 74mm extrusions from the beginning if you left them installed.

### Belt Tensioning



Created by:  
Joshua Vasquez

last edited:  
6/1/2020

SCALE: 1:10

SHEET 17 OF 17