

2

1

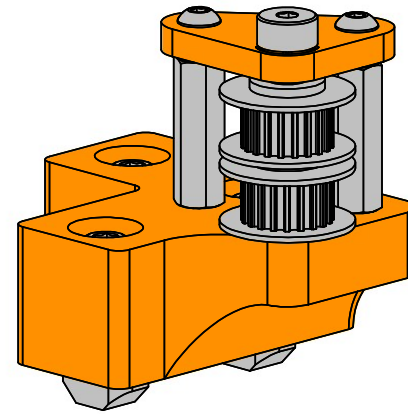
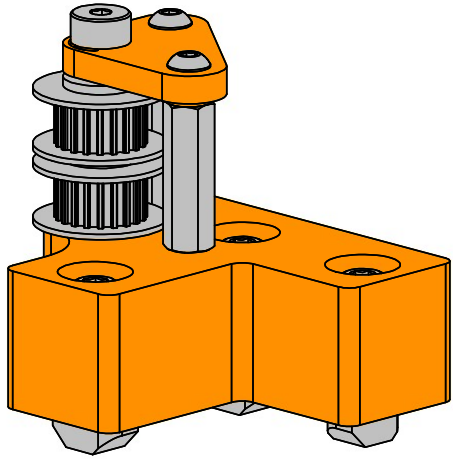

B

B

A

A

2

1

Double Pulley Corner Plate Assembly



Created by:
Joshua Vasquez

last edited:
5/31/2020

SCALE: 1:1

SHEET 1 OF 7

NOTE: This assembly step is for **generic** brand pulleys only. If you are using genuine **Gates** brand pulleys, skip this page and see the next page.

Note the plate orientation!

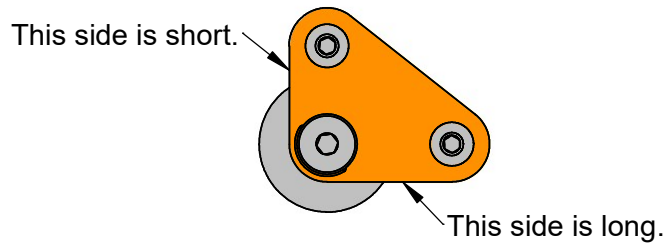

Top View

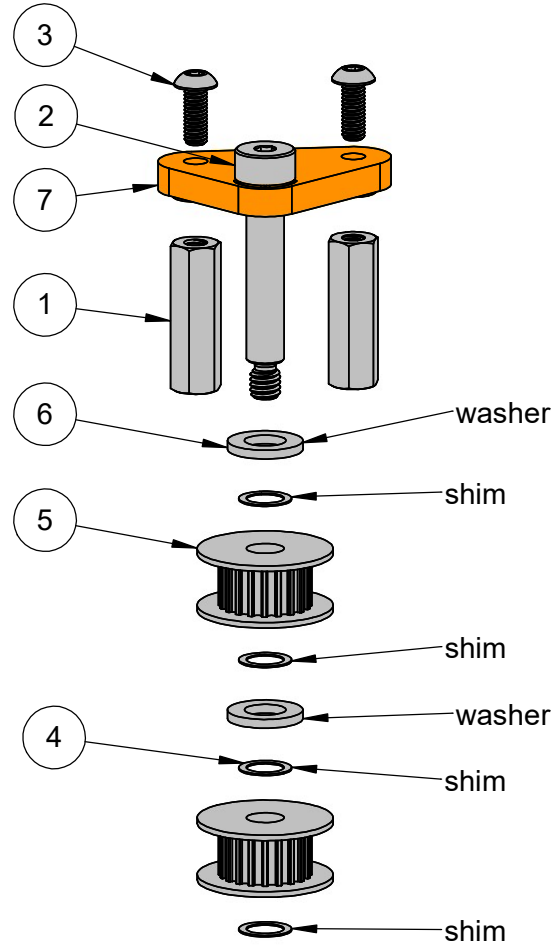

Exploded View

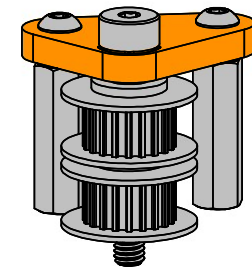

Assembled View

ITEM NO.	DESCRIPTION	
1	M3 Standoff, 20mm long, 6mm wide	2
2	M4 Shoulder Screw, 25mm long	1
3	M3 Buttonhead Screw, 8mm long	2
4	M5 Shim, 0.2mm thick, 7mm OD	4
5	20T Idler pulley, 2GT, 5mm bore	2
6	M5 Washer, 0.8-1.2mm thick	2
7	Left Corner Pulley Reinforcement Plate	1

Left Corner Generic Pulley Assembly



Created by:
Joshua Vasquez

last edited:
5/31/2020

SCALE: 1:1

SHEET 2 OF 7

NOTE: This assembly step is for **Gates** brand pulleys only. If you are using **generic** brand pulleys, skip this page and see the previous page.

B

B

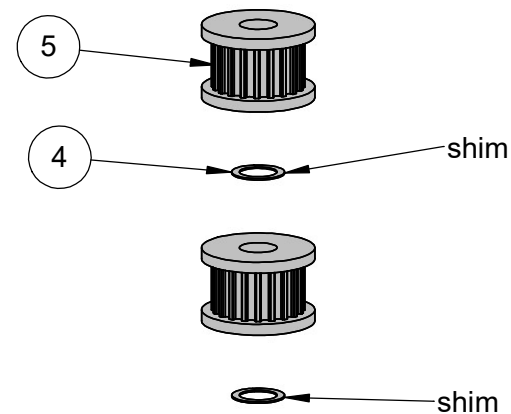
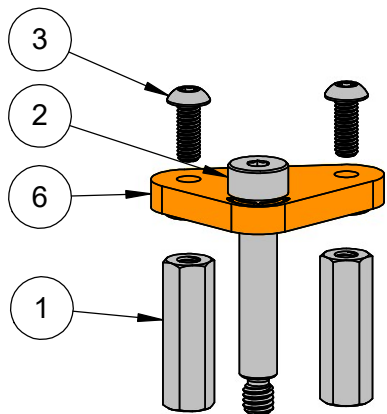
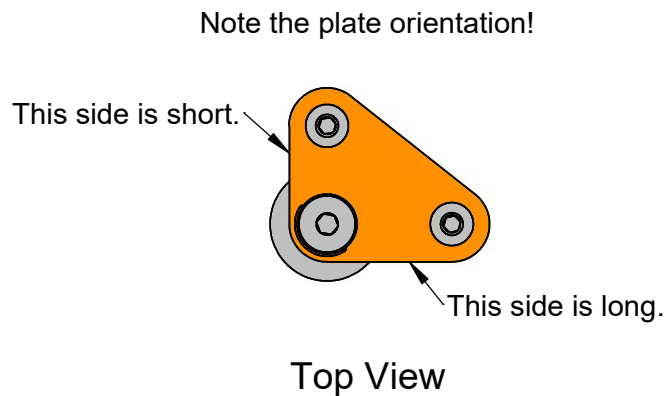

Exploded View

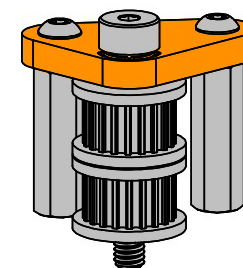

Assembled View

A

A

ITEM NO.	DESCRIPTION	QTY.
1	M3 Standoff, 20mm long, 6mm wide	2
2	M4 Shoulder Screw, 25mm long	1
3	M3 Buttonhead Screw, 8mm long	2
4	M5 Shim, 0.2mm thick, 7mm OD	2
5	20T Idler pulley, 2GT, 5mm bore	2
6	Left Corner Pulley Reinforcement Plate	1

Left Corner Gates Pulley Assembly

	Created by: Joshua Vasquez	last edited: 5/31/2020
	SCALE: 1:1	SHEET 3 OF 7

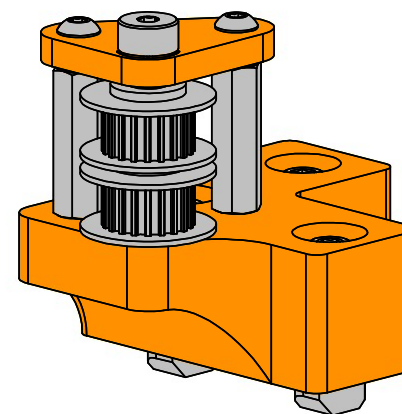
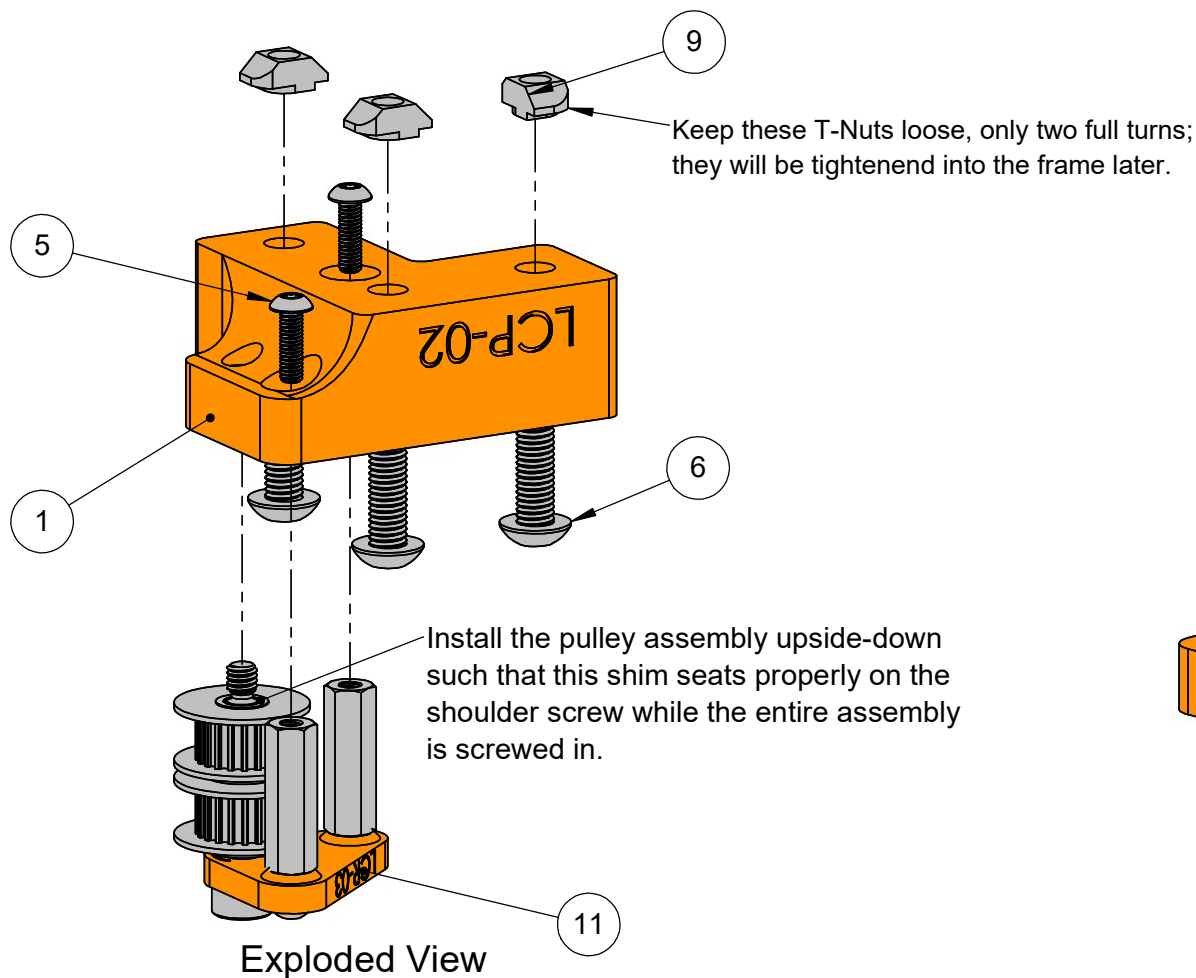

ITEM NO.	DESCRIPTION	
1	Left Corner Plate with Insert Installed	1
5	M3 Buttonhead Screw, 10mm long	2
6	M5 Buttonhead Screw, 20mm long	3
9	M5 Drop-In T-Nut for 20x20 Extrusion	3
11	Left Corner Pulley Reinforcement Plate	1

Left Corner Pulley Plate Assembly		
	Created by:	last edited:
	Joshua Vasquez	5/31/2020
	SCALE: 1:1	SHEET 4 OF 7

NOTE: This assembly step is for **generic** brand pulleys only. If you are using genuine **Gates** brand pulleys, skip this page and see the next page.

B

Top View

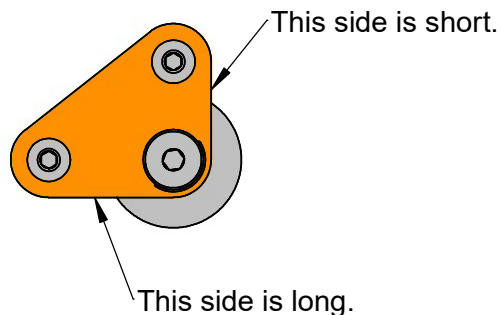

Note the plate orientation! Also note that this orientation is different from the prior pulley assembly.

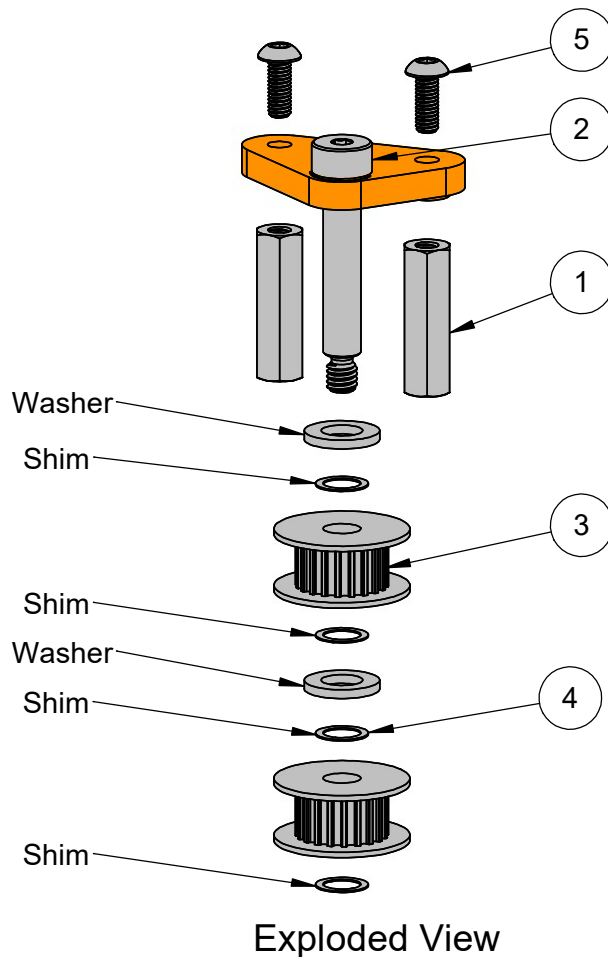

Exploded View

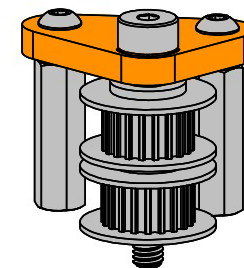

Assembled View

B

A

ITEM NO.	DESCRIPTION	
1	M3 Standoff, 20mm long, 6mm wide	2
2	M4 Shoulder Screw, 25mm long	1
3	20T Idler pulley, 2GT, 5mm bore	2
4	M5 Shim, 0.2mm thick, 7mm OD	4
5	M3 Buttonhead Screw, 8mm long	2
6	M5 Washer, 0.8-1.2mm thick	2
7	Left Corner Pulley Reinforcement Plate	1

Right Corner Generic Pulley Assembly



Created by:
Joshua Vasquez

last edited:
5/31/2020

SCALE: 1:1

SHEET 5 OF 7

A

NOTE: This assembly step is for **Gates** brand pulleys only. If you are using **generic** brand pulleys, skip this page and see the previous page.

Top View

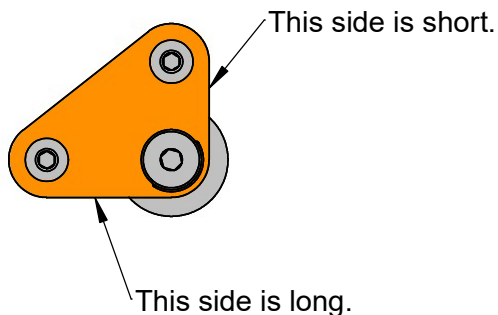

Note the plate orientation! Also note that this orientation is different from the prior pulley assembly.

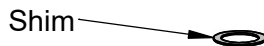
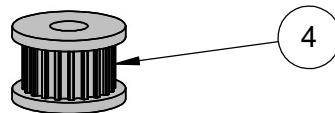
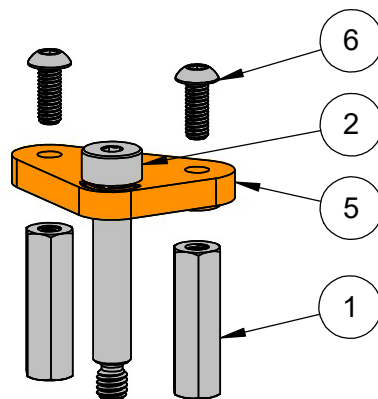

Exploded View

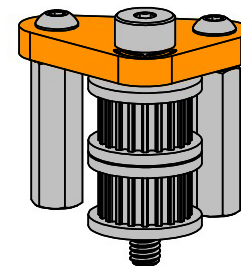

Assembled View

ITEM NO.	DESCRIPTION	QTY.
1	M3 Standoff, 20mm long, 6mm wide	2
2	M4 Shoulder Screw, 25mm long	1
3	M5 Shim, 0.2mm thick, 7mm OD	2
4	20T Idler pulley, 2GT, 5mm bore	2
5	Left Corner Pulley Reinforcement Plate	1
6	M3 Buttonhead Screw, 8mm long	2

Right Corner Gates Pulley Assembly



Created by:
Joshua Vasquez

last edited:
5/31/2020

SCALE: 1:1

SHEET 6 OF 7

B

B

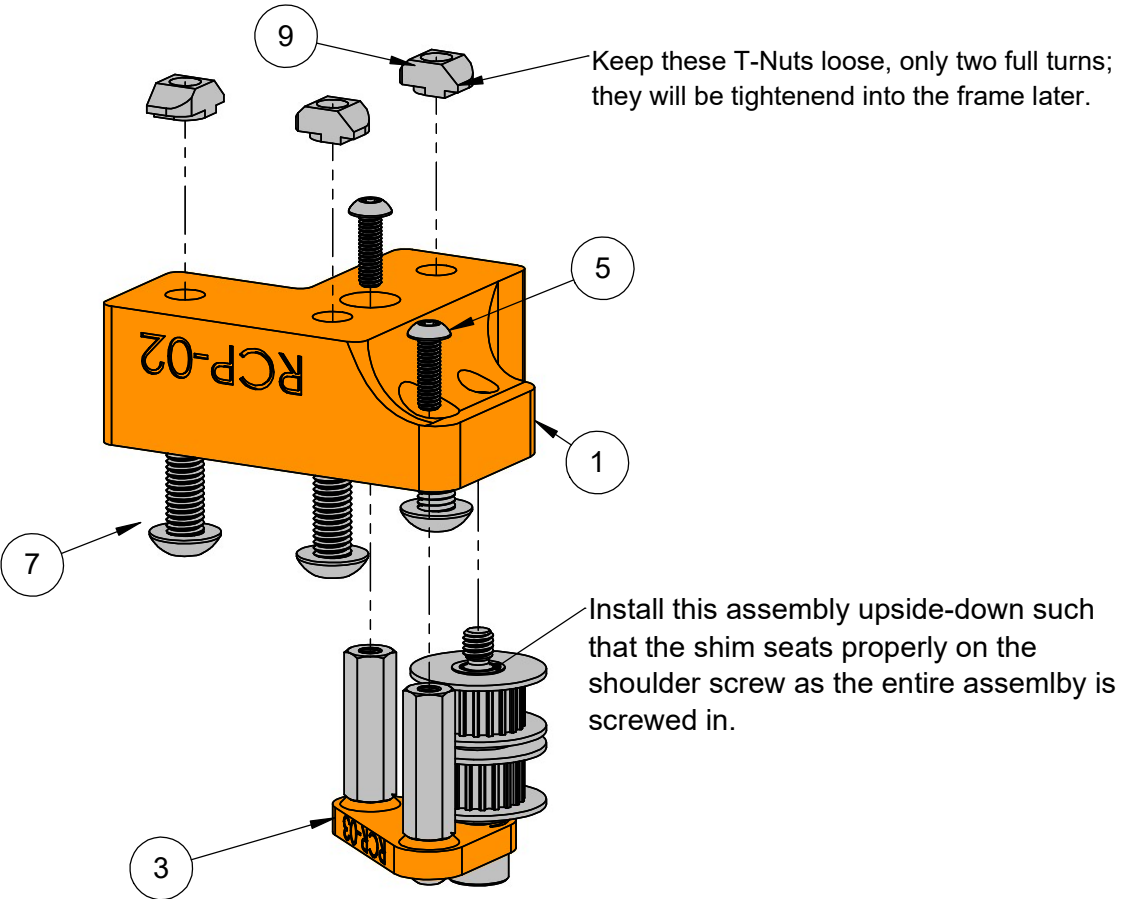

Exploded View

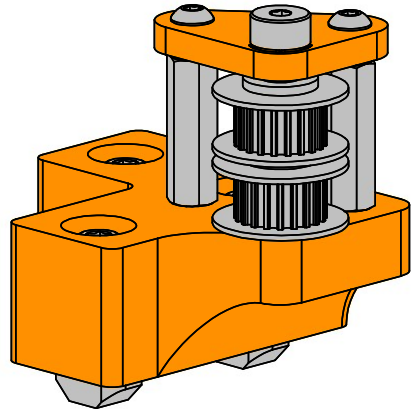

Assembled View

A

A

ITEM NO.	DESCRIPTION	
1	Right Corner Plate with Insert Installed	1
3	Right Corner Pulley Assembly	1
5	M3 Buttonhead Screw, 10mm long	2
7	M5 Buttonhead Screw, 20mm long	3
9	M5 Drop-In T-Nut for 20x20 Extrusion	3

Right Corner Pulley Plate Assembly

	Created by:	last edited:
	Joshua Vasquez	5/31/2020
SCALE: 1:1		SHEET 7 OF 7

2

1

2

1