

2

1

B

B

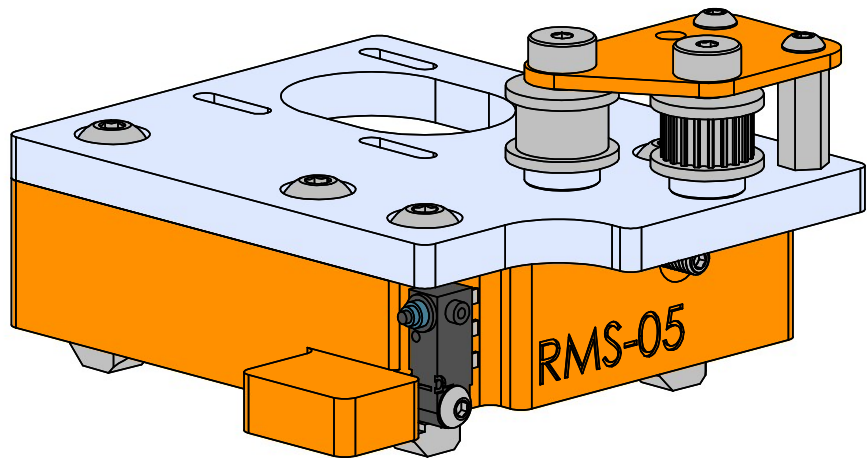
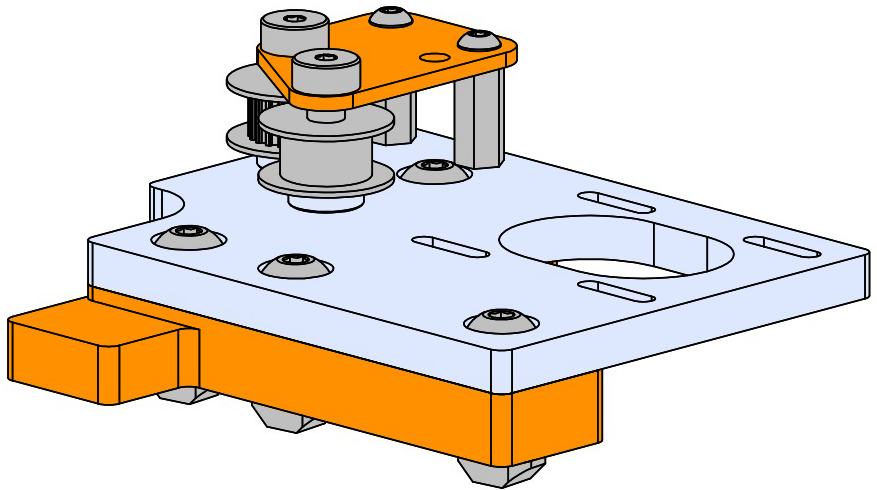

A

A

2

1

Machined Motor Plate Assembly Instructions



Created by:  
Joshua Vasquez

last edited:  
5/31/2020

SCALE: 1:1

SHEET 1 OF 11

2

1

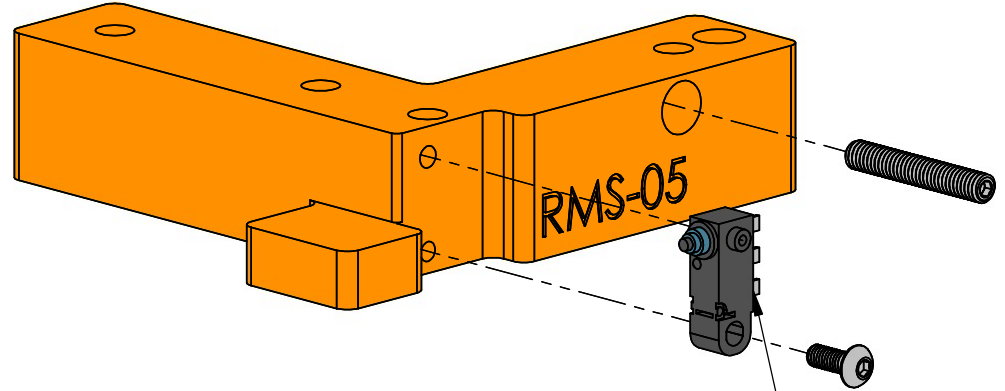
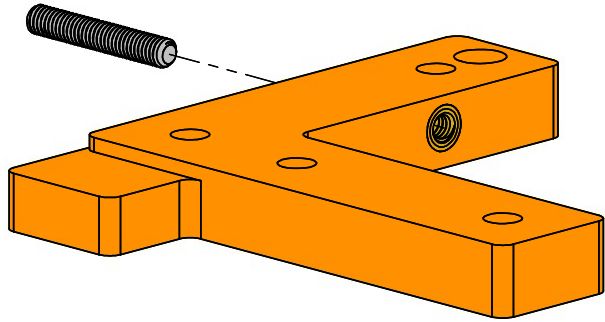

Exploded Views

solder in wires first!

On each set screw, just install the screw until it is flush with the inside surface. If there is residual 3D printed gunk from the heat-set installation process, you can clear it by installing the screw backwards first.

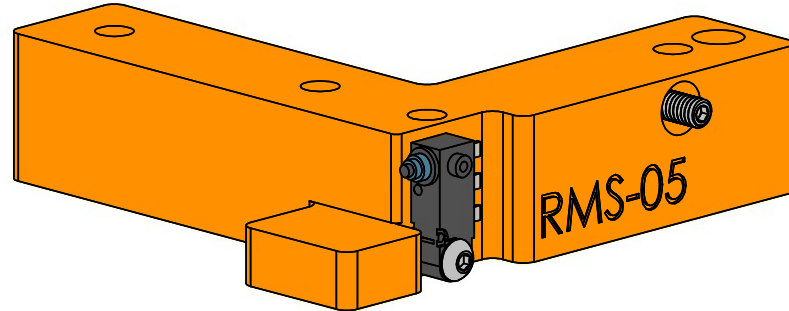
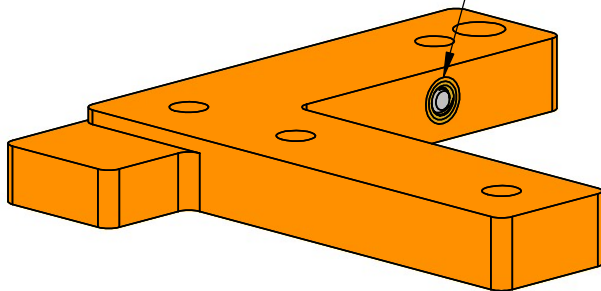

Assembled Views

ITEM NO.	DESCRIPTION	QTY.
1	Short Motor Spacer with Insert	1
2	Tall Motor Spacer with Insert	1
3	Y Axis Limit Switch with Harness	1
4	M4 Set Screw, 25mm long	2
5	M3 Buttonhead Screw, 8mm long	1

Spacer Assembly		
	Created by:	last edited:
	Joshua Vasquez	5/31/2020
SCALE: 1:1		SHEET 2 OF 11

2

1

2

1

Make two identical assemblies.

B

B

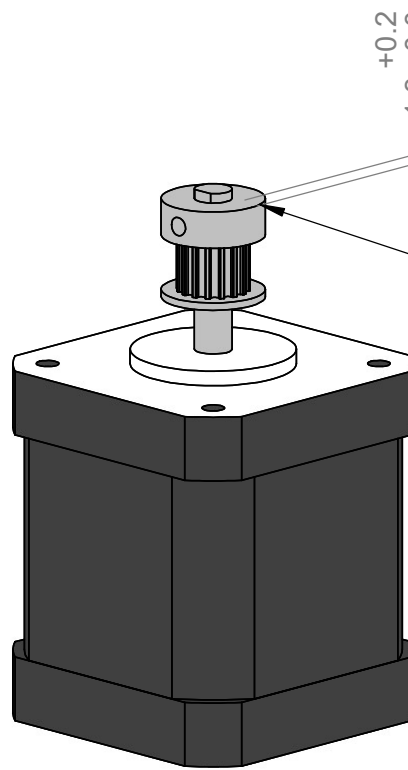

+0.2  
1.3 0.0

Secure both included set screws onto the shaft, ensuring that one set screw engages the flat part of the shaft.

The vertical pulley spacing can be dialed in exactly later.

A

A

ITEM NO.	DESCRIPTION	QTY.
1	16-T 2GT Drive Pulley for 6mm belt	1
2	Nema17 XY Stepper: LDO-42STH60-2004MAC or 17HM19-2004S	1

Sheet1		
	Created by: Joshua Vasquez	last edited: 5/31/2020
	SCALE: 1:1	SHEET 3 OF 11

2

1

2

1

B

B

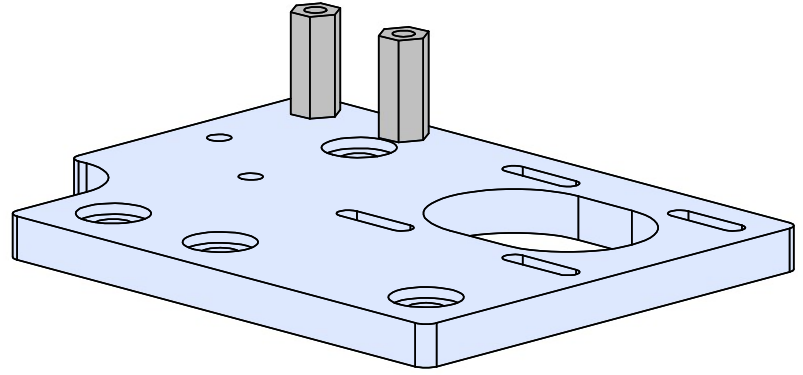
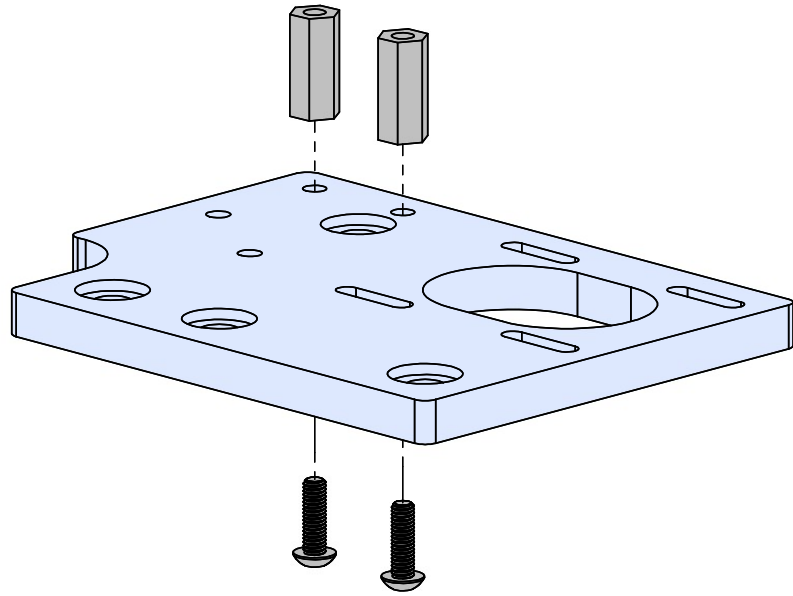

A

A

ITEM NO.	DESCRIPTION	
1	M3 Standoff, 14mm long, 6mm wide	2
2	M3 Buttonhead Screw, 10mm long	2
3	Machined Left Motor Corner Bracket	1

**Left Motor Plate Assembly 1/4**

	Created by: Joshua Vasquez	last edited: 5/31/2020
	SCALE: 1:1	SHEET 4 OF 11

2

1

2

1

B

B

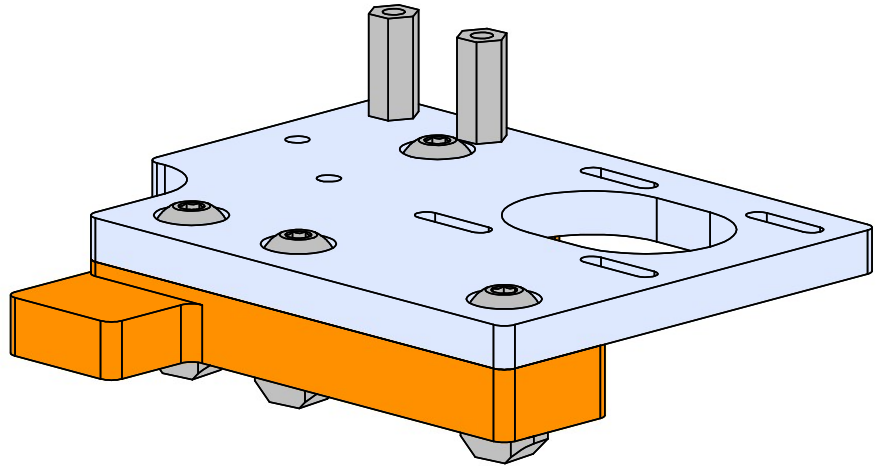
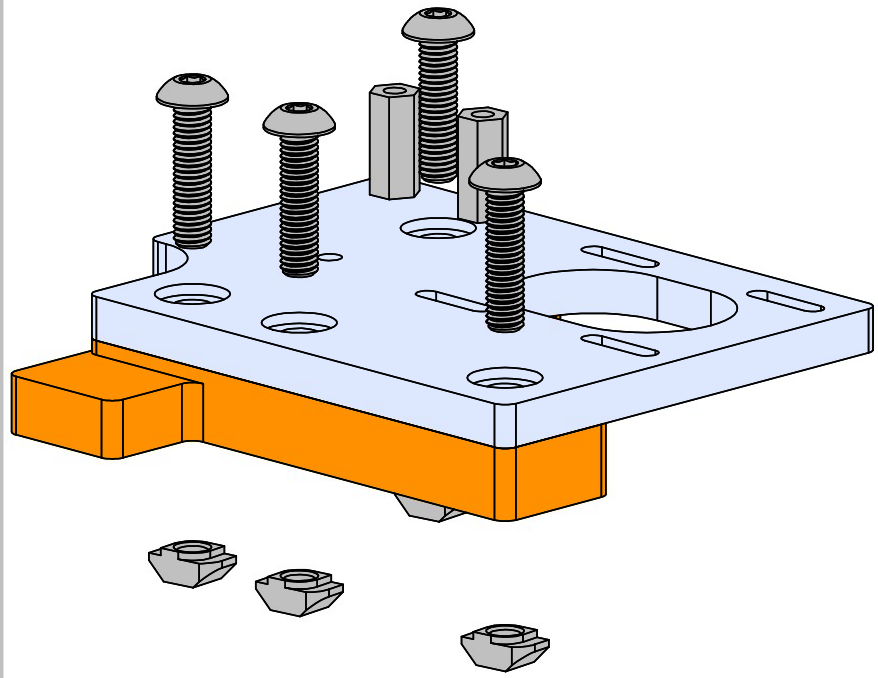

A

A

ITEM NO.	DESCRIPTION	
4	M5 Buttonhead Screw, 20mm long	4
5	M5 Drop-In T-Nut for 20x20 Extrusion	4
6	Left Motor Spacer	1

**Left Motor Plate Assembly 2/4**

	Created by:	last edited:
	Joshua Vasquez	5/31/2020
SCALE: 1:1		SHEET 5 OF 11

2

1

2

1

These pulleys can be either Gates brand or Generic 2GT, provided that they are between 8.5 and 10mm tall.

B

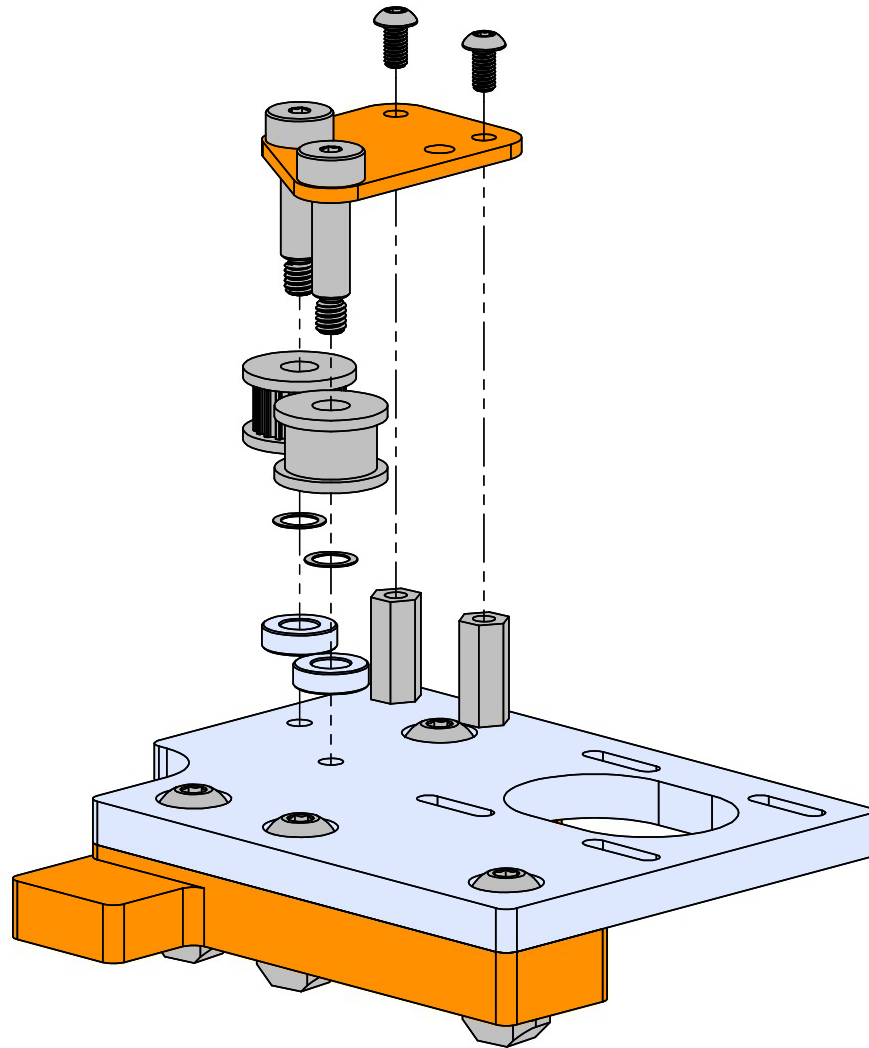

B

A

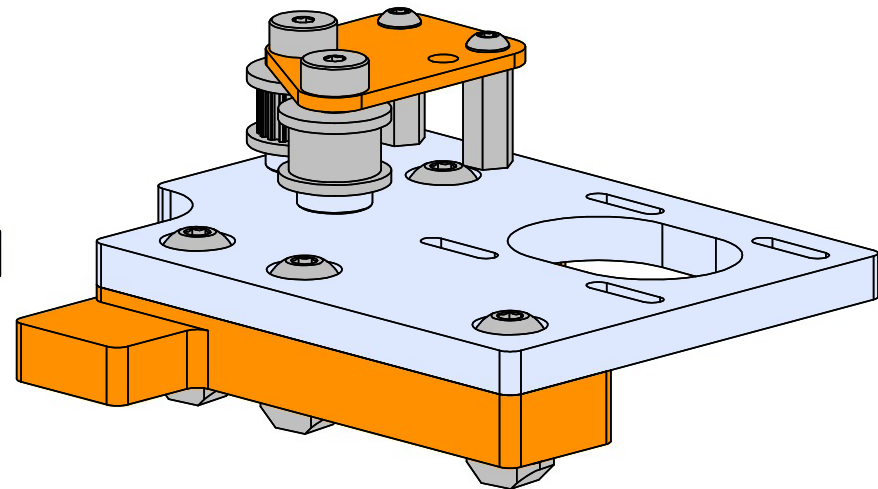

A

ITEM NO.	DESCRIPTION	QTY
5	OpenBuilds M5 3mm Spacer	2
6	M5 Shim, 0.2mm thick, 7mm OD	2
7	pulley reinforcement plate for motor	1
8	M4 Shoulder Screw, 16mm-l, 5mm-d	2
9	M3 Buttonhead Screw, 6mm long	2
11	20T toothless idler, 5mm bore	1
12	20T Idler pulley, 2GT, 5mm bore	1

#### Left Motor Plate Assembly 3/4



Created by:  
Joshua Vasquez

last edited:  
5/31/2020

SCALE: 1:1

SHEET 6 OF 11

2

1

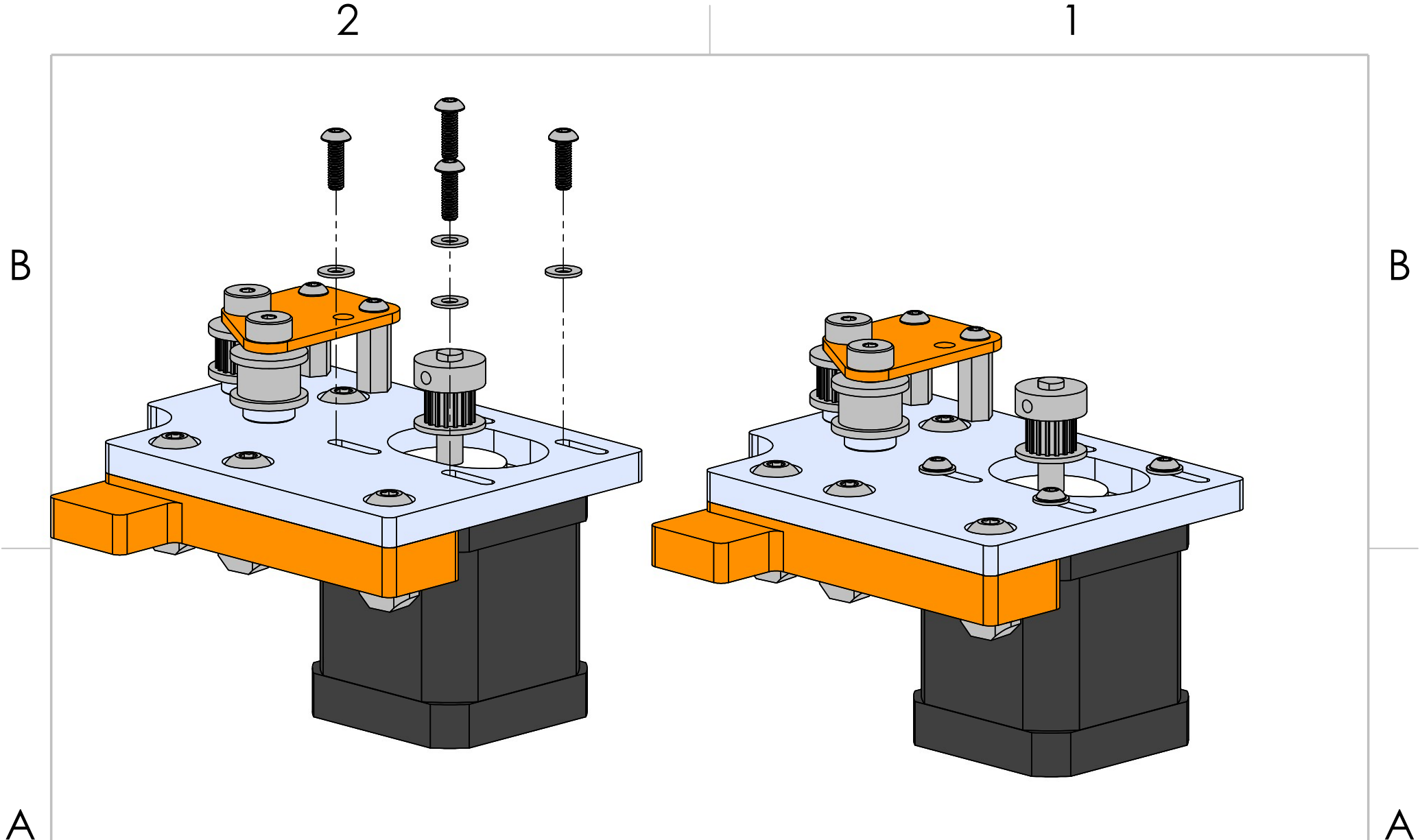

ITEM NO.	DESCRIPTION	
2	M3 Buttonhead Screw, 10mm long	6
11	M3 Washer	4
12	Stepper Motor with Drive Pulley	1

**Left Motor Plate Assembly 4/4**

	Created by:	last edited:
	Joshua Vasquez	5/31/2020
SCALE: 1:1		SHEET 7 OF 11

2

1

2

1

B

B

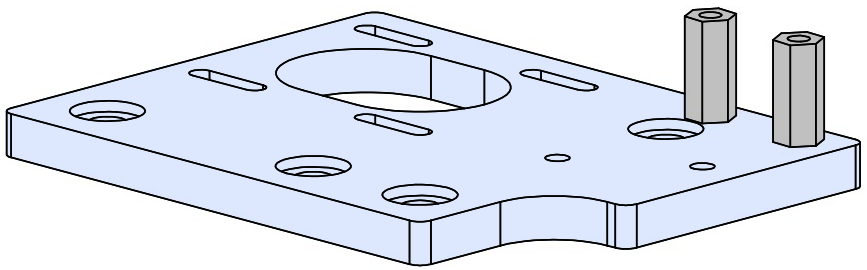
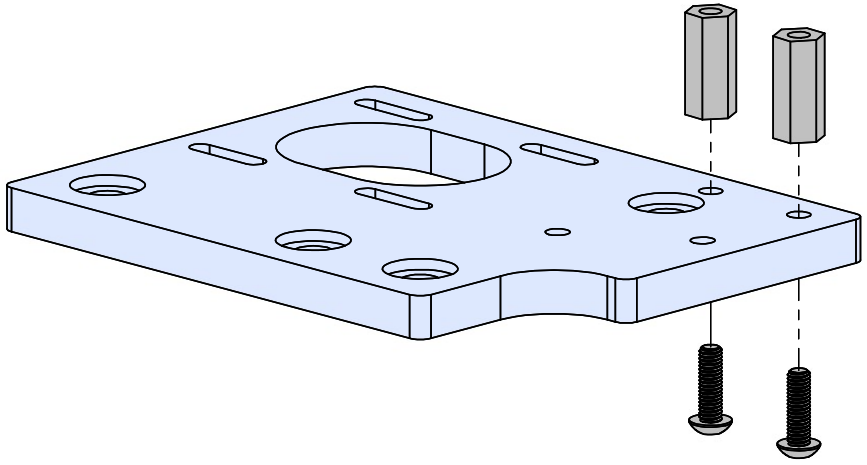

A

A

ITEM NO.	DESCRIPTION	
1	Machined Right Motor Corner Bracket	1
2	M3 Standoff, 14mm long, 6mm wide	2
3	M3 Buttonhead Screw, 10mm long	2

<b>Right Motor Plate Assembly 1/4</b>		
	Created by:	last edited:
	Joshua Vasquez	5/31/2020
	SCALE: 1:1	SHEET 8 OF 11

2

1



2

1

ITEM NO.	DESCRIPTION	
3	Tall Motor Corner Plate Spacer Assembly	1
4	M5 Buttonhead Screw, 30mm long	4
5	M5 Drop-In T-Nut for 20x20 Extrusion	4

B

B

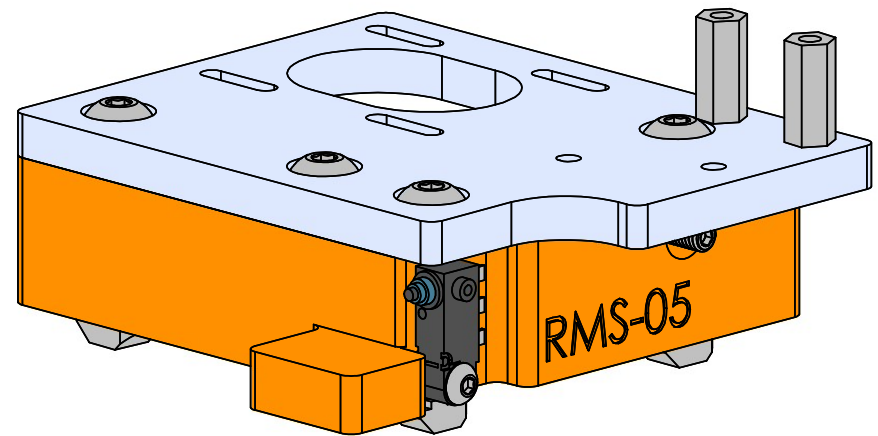
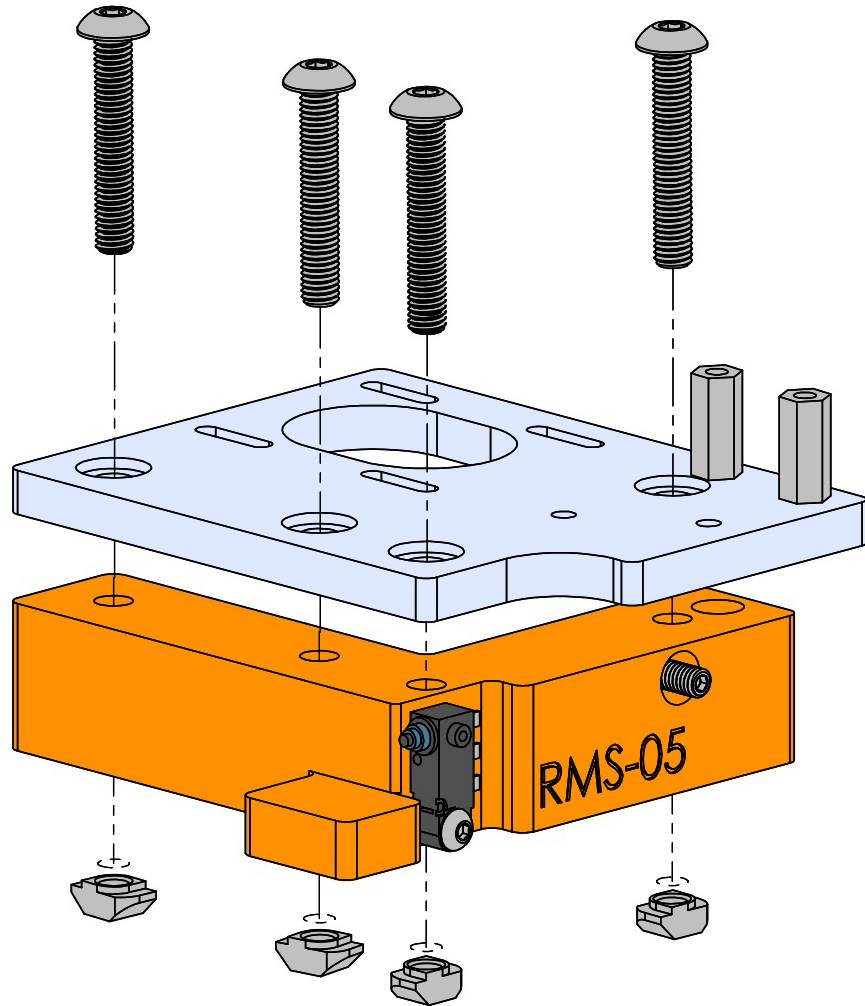

A

A

### Right Motor Plate Assembly 2/4



Created by:  
Joshua Vasquez

last edited:  
5/31/2020

SCALE: 1:1

SHEET 9 OF 11

2

1

These pulleys can be either Gates brand or Generic 2GT, provided that they are between 8.5 and 10mm tall.

B

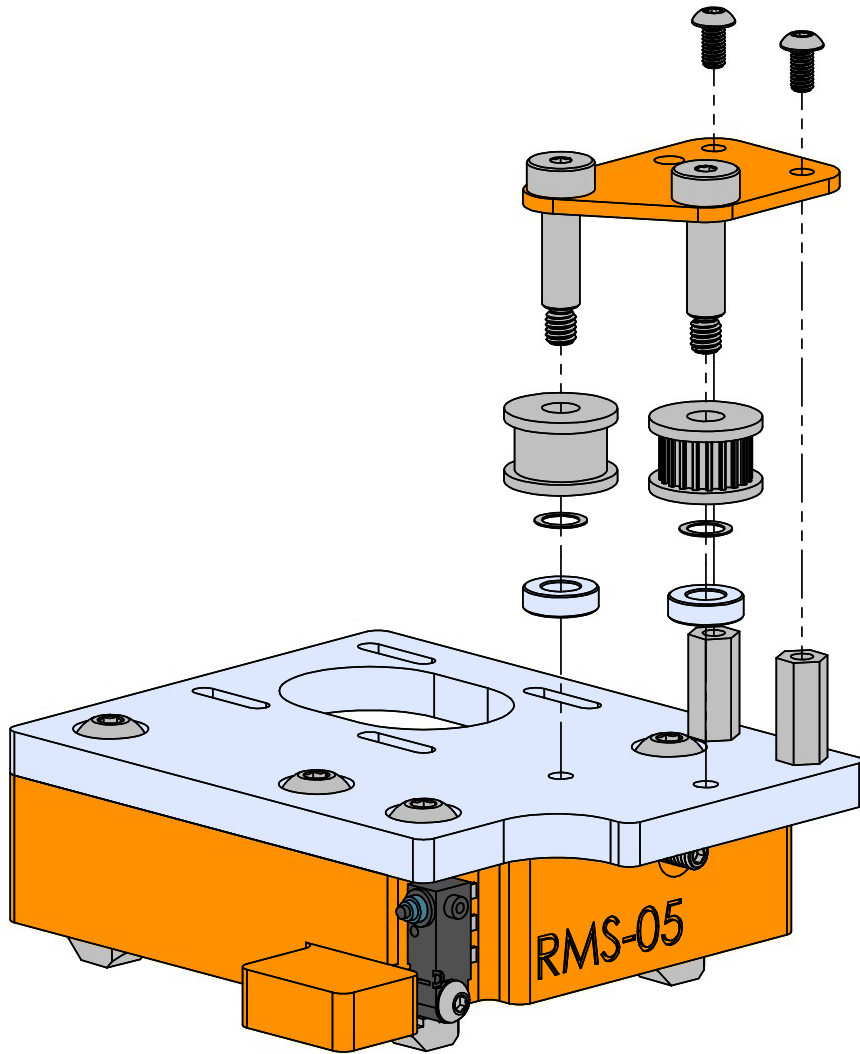

A

ITEM NO.	DESCRIPTION	
3	20T Idler pulley, 2GT, 5mm bore	1
4	20T toothless idler, 5mm bore	1
5	pulley reinforcement plate for motor	1
6	M3 Buttonhead Screw, 6mm long	2
7	M4 Shoulder Screw, 16mm-l, 5mm-d	2
8	M5 Shim, 0.2mm thick, 7mm OD	2
9	OpenBuilds M5 3mm Spacer	2

B

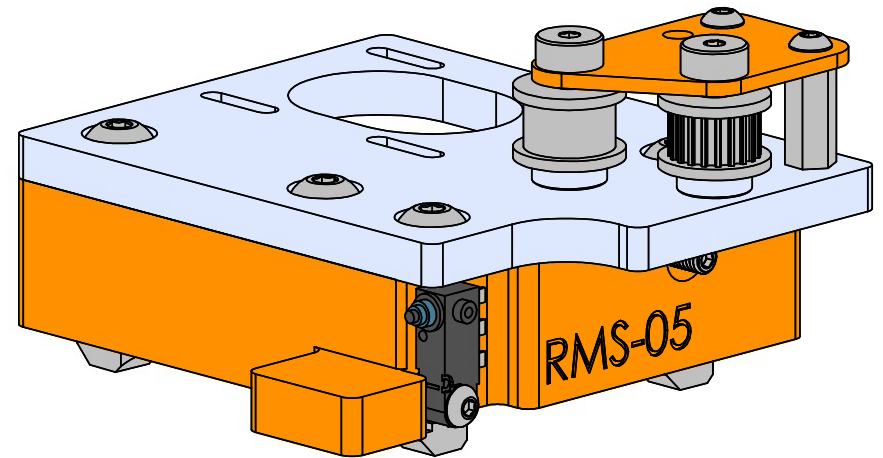

A

Right Motor Plate Assembly 3/4



Created by:  
Joshua Vasquez

last edited:  
5/31/2020

SCALE: 1:1

SHEET 10 OF 11

2

1

B

B

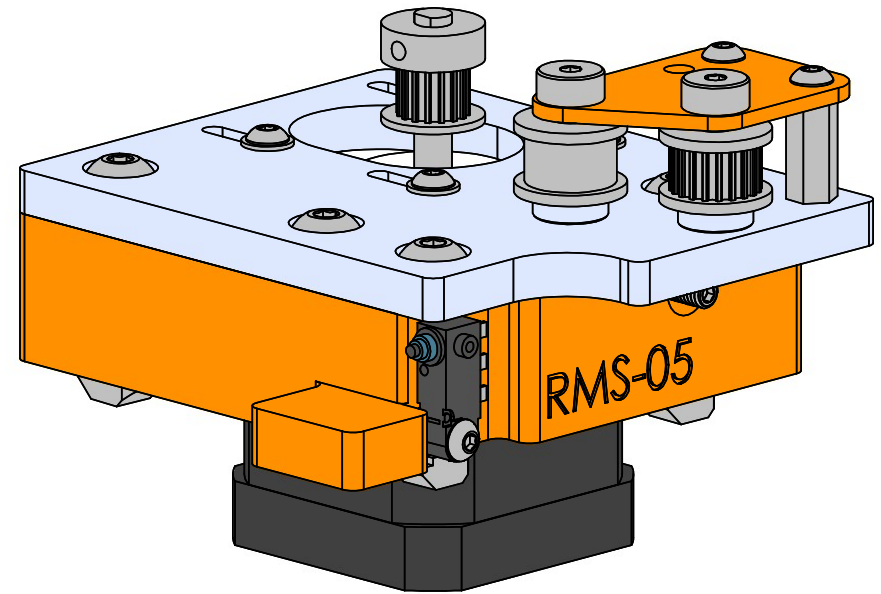
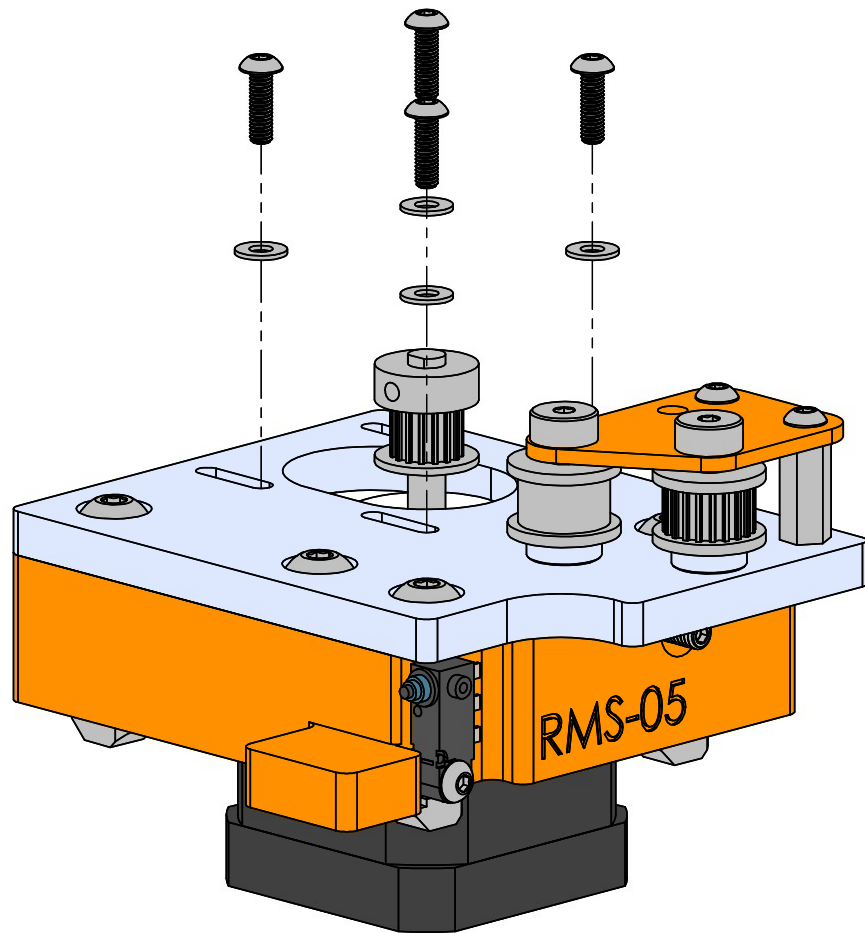

A

A

ITEM NO.	DESCRIPTION	QTY
11	M3 Buttonhead Screw, 10mm long	6
12	Stepper Motor with Drive Pulley	1
13	M3 Washer	4
14	20T Idler pulley, 2GT, 5mm bore	1
15	20T Toothless Idler pulley, 2GT, 5mm bore	1

#### Right Motor Plate Assembly 4/4



Created by:  
Joshua Vasquez

last edited:  
5/31/2020

SCALE: 1:1

SHEET 11 OF 11

2

1