

2

1

B

B

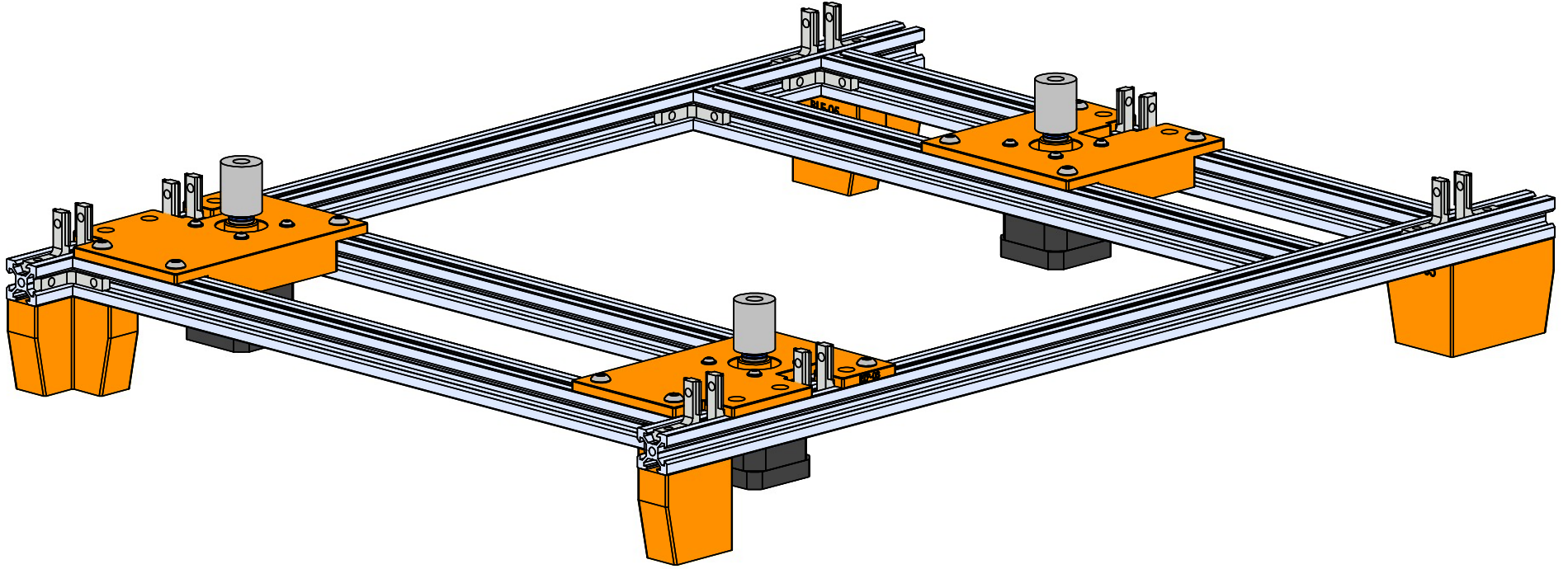

A

A

2

1

Lower Frame Assembly



Created by:
Joshua Vasquez

last edited:
6/27/2020

SCALE: 1:3

SHEET 1 OF 14

2

1

Populate all screw holes with screws and nuts

Keep all nuts loose. Only 1-2 turns. They will be fully tightened into the frame later.

B

B

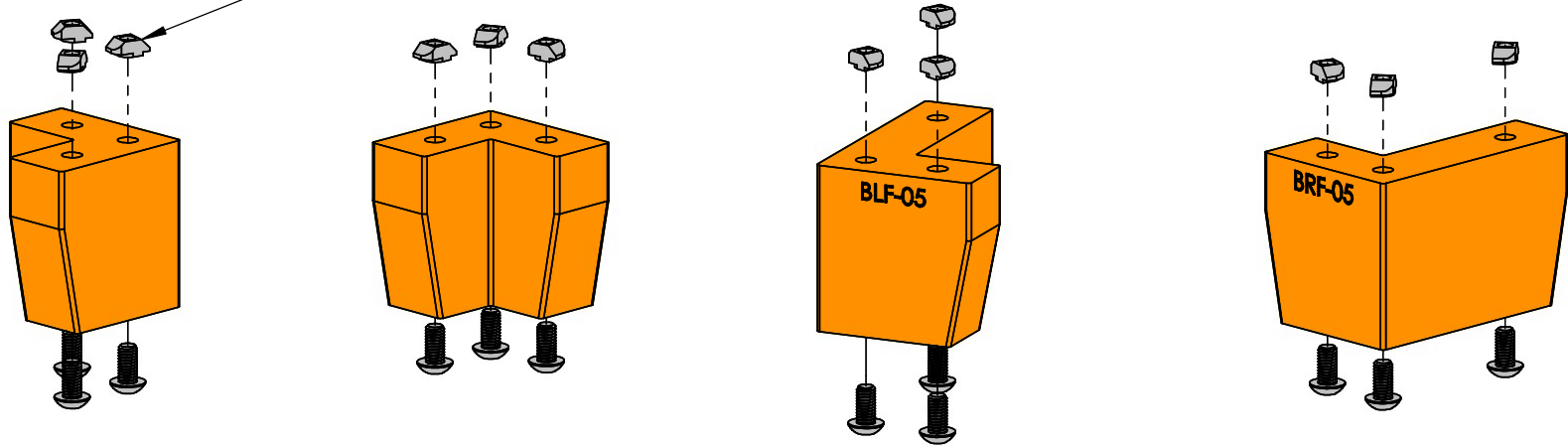

Exploded Views

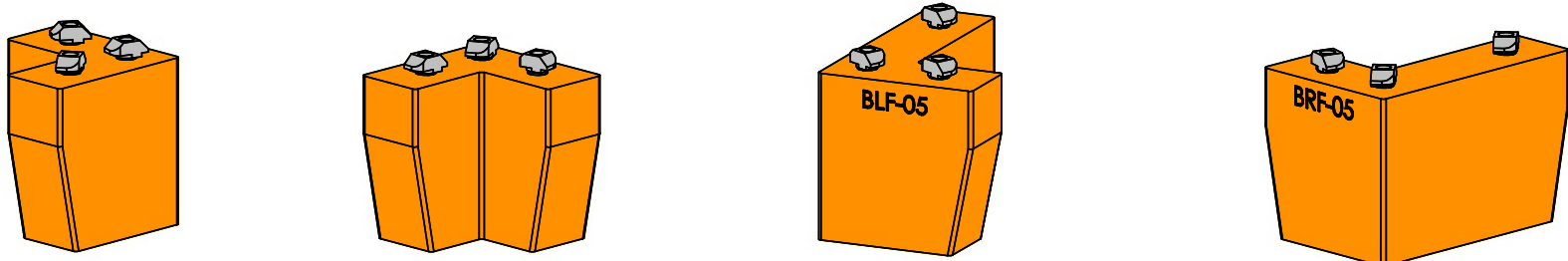

Assembled Views

A

A

ITEM NO.	DESCRIPTION	QTY.
1	Back Right Foot	1
2	Back Left Foot	1
3	Front Right Foot	1
4	Front Left Foot	1
5	M5 Drop-In T-Nut for 20x20 Extrusion	12
6	M5 Buttonhead Screw, 10mm long	12

Foot Screw Installation



Created by:
Joshua Vasquez

last edited:
6/27/2020

SCALE: 1:2

SHEET 2 OF 14

2

1

2

1

Fully tighten the feet into the four corners shown below. (It may be easier to prop the frame up vertically to do the installation.)

B

B

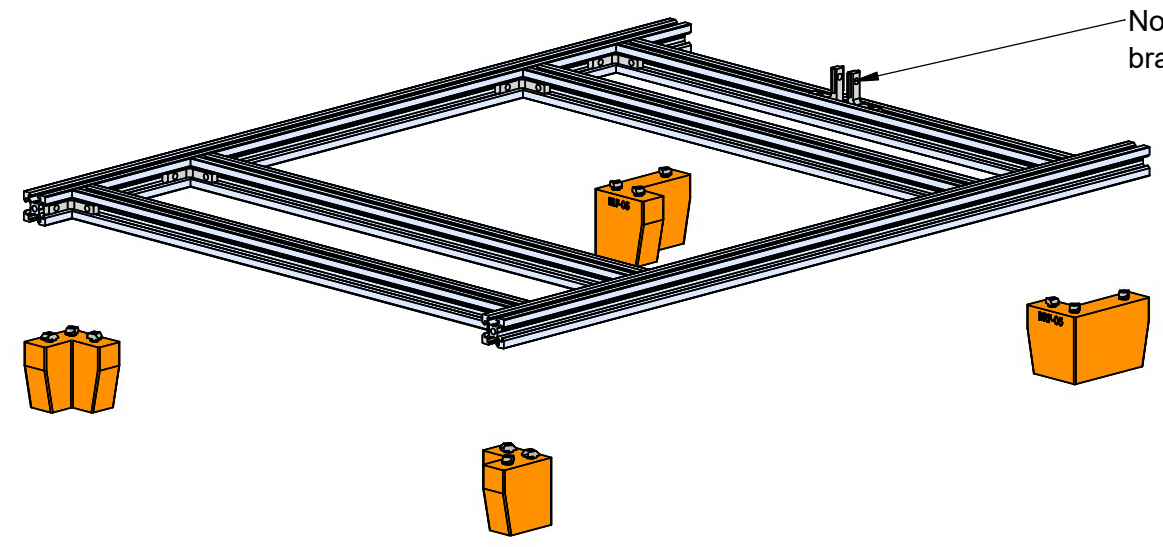

Exploded View

A

A

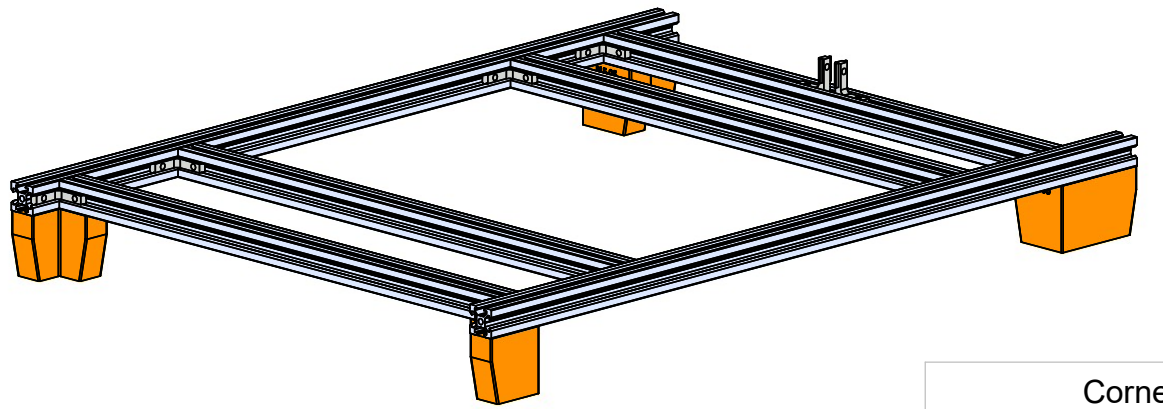

Assembled View

2

1

Corner Foot Installation		
	Created by:	last edited:
	Joshua Vasquez	6/27/2020
	SCALE: 1:5	SHEET 3 OF 14

2

1

Make 3 Assemblies.

These are a 3 piece set.
Orientation of each piece
does not matter.

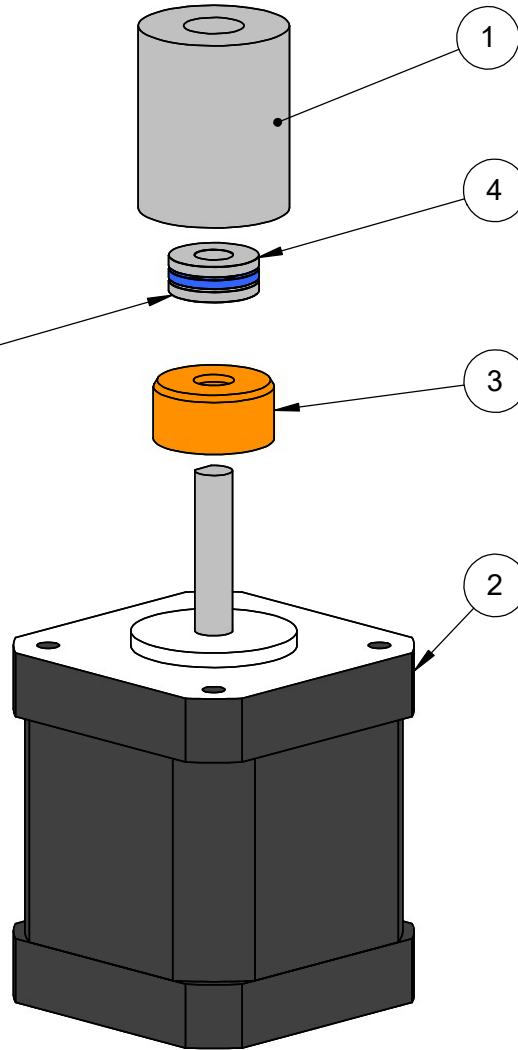

Exploded View

With one hand, compress the coupler
onto the motor shaft to remove any
space on the motor shaft. Securely
screw down the coupler in this
configuration.

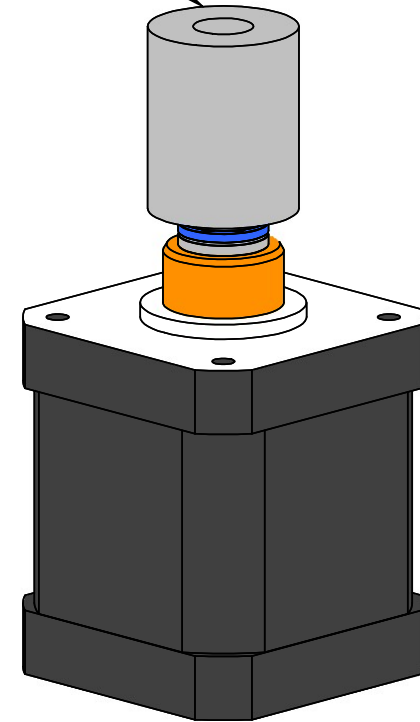

Assembled View

ITEM NO.	DESCRIPTION	QTY.
1	5mm to 8mm flexible plumb coupler	1
2	Nema 17 Stepper Motor	1
3	Z Thrust Bearing Spacer	1
4	5mm Oversize Thrust Bearing	1

Z Motor Thrust Coupling Assembly		
	Created by: Joshua Vasquez	last edited: 6/27/2020
	SCALE: 1:1	SHEET 4 OF 14

2

1

2

1

B

B

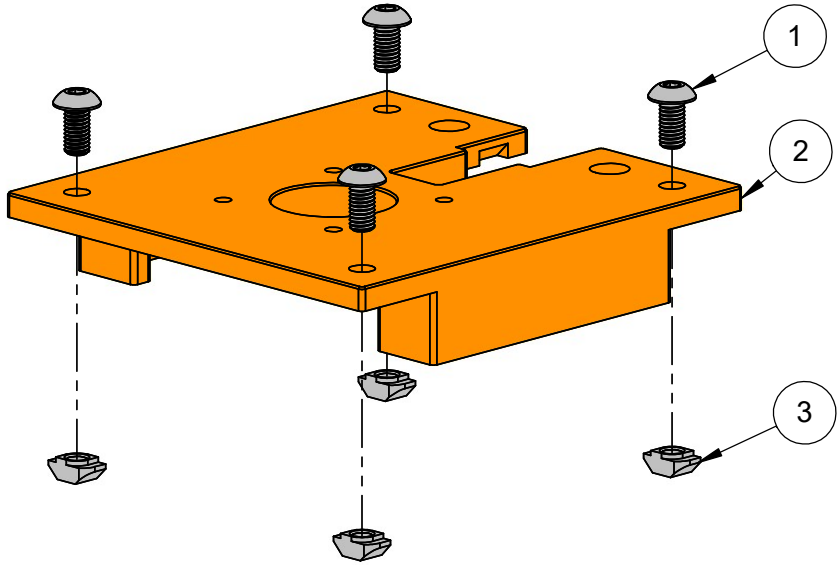

Exploded View

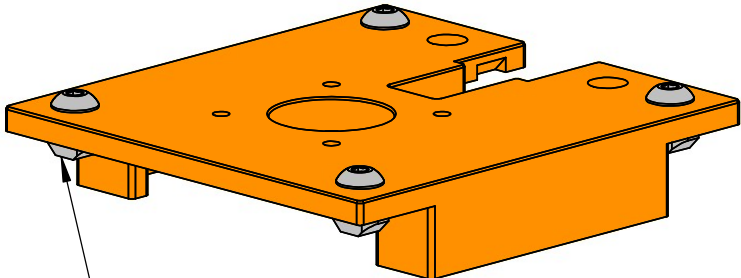

Assembled View

Keep these T-Nuts Loose; only two full turns. They will be tightened into the frame later.

A

A

ITEM NO.	DESCRIPTION	QTY.
1	M5 Buttonhead Screw, 10mm long	4
2	Back Z Motor Plate	1
3	M5 Drop-In T-Nut for 20x20 Extrusion	4

Back Z Motor Plate Assembly 1

	Created by: Joshua Vasquez	last edited: 6/27/2020
	SCALE: 1:1.5	SHEET 5 OF 14

2

1

2

1

Apply a dab of threadlock to the tip of the four M3 screws before tightening them down securely.

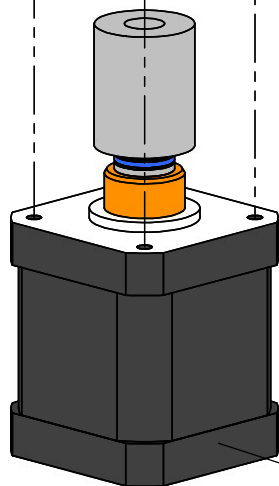
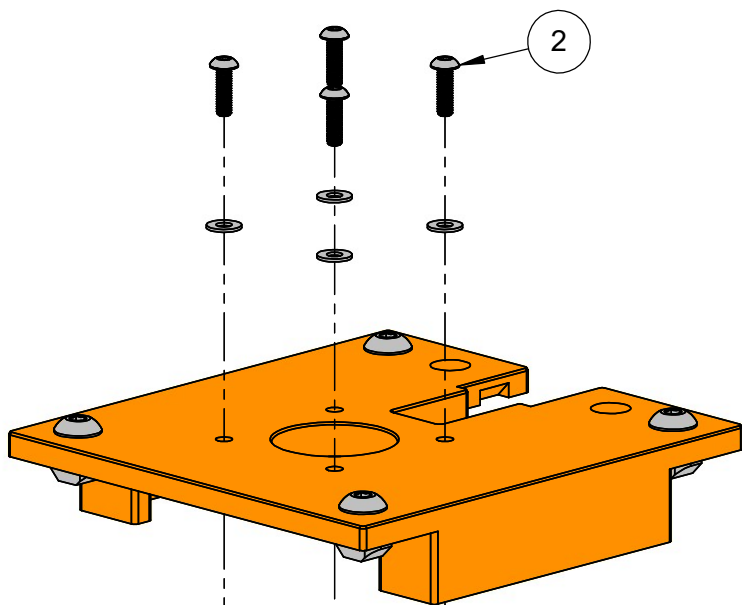

Exploded View

Wires should stick out in this direction.

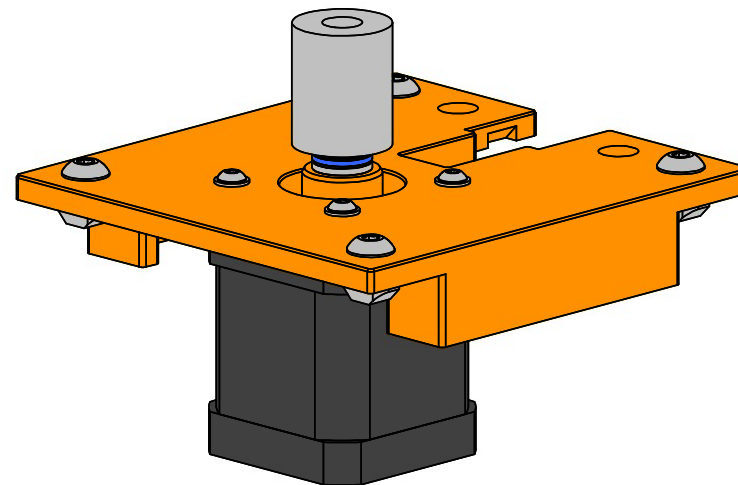

Assembled View

ITEM NO.	DESCRIPTION	QTY.
2	M3 Buttonhead Screw, 10mm long	4
3	Back Plate Plate Assembly	1
5	Z Motor Thrust Coupling Assembly	1
6	M3 Washer	4

Back Z Motor Plate Assembly 2



Created by:
Joshua Vasquez

last edited:
6/27/2020

SCALE: 1:1.5

SHEET 6 OF 14

2

1

B

B

A

A

2

1

B

B

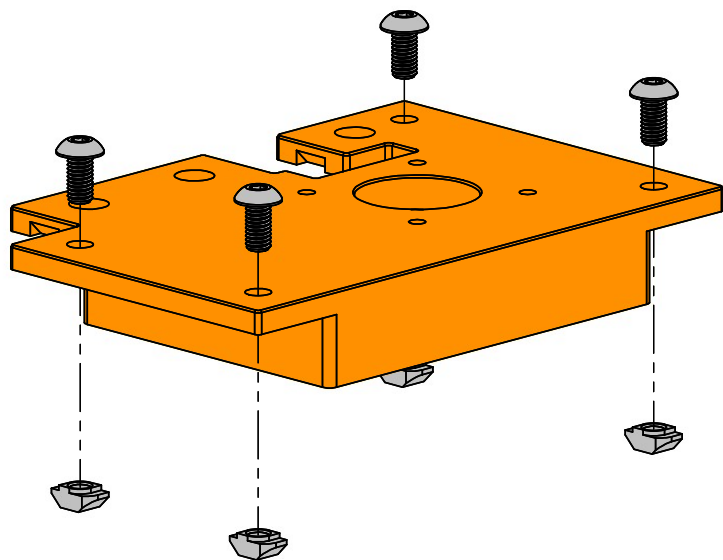

Exploded View

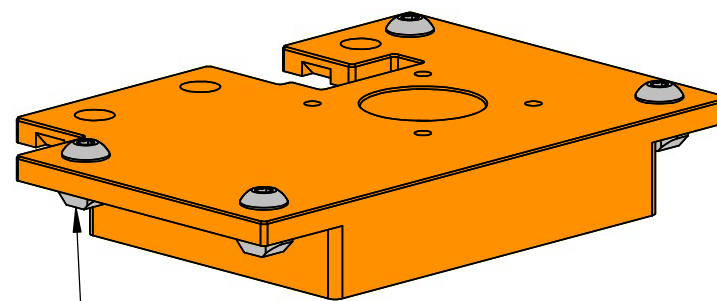

Assembled View

Keep these T-Nuts Loose; only two full turns.
They will be tightened into the frame later.

A

A

ITEM NO.	DESCRIPTION	QTY.
1	M5 Buttonhead Screw, 10mm long	4
2	Front Left Z Motor Plate	1
3	M5 Drop-In T-Nut for 20x20 Extrusion	4

Front Left Z Plate Assembly 1



Created by:
Joshua Vasquez

last edited:
6/27/2020

SCALE: 1:1.5

SHEET 7 OF 14

2

1

2

1

Apply a dab of threadlock to the tip of the four M3 screws before tightening them down securely.

B

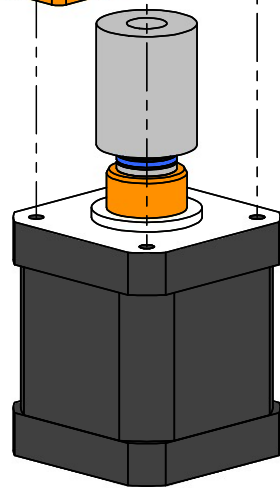
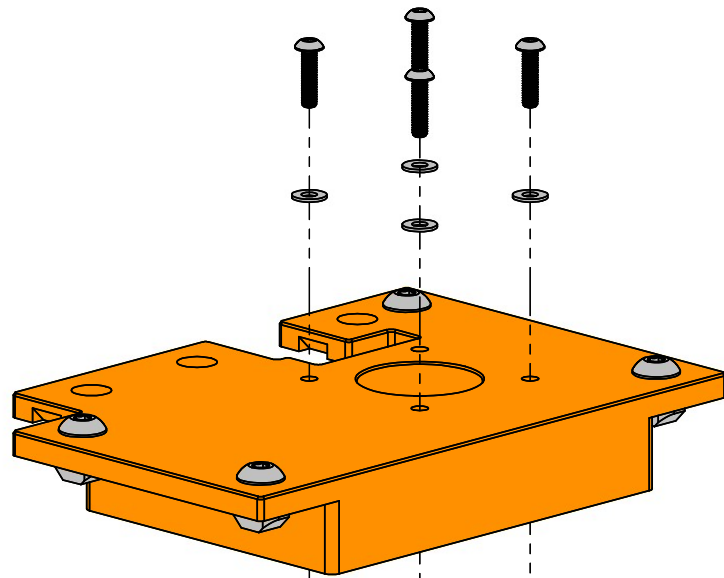

Wires should stick out in this direction.

Exploded View

Motor wires should poke up and out from this cavity.

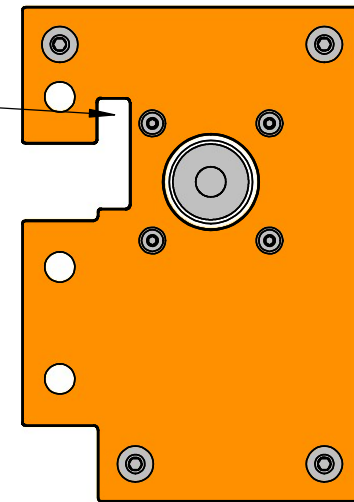
Assembled Top View
Scale 1:2

B

A

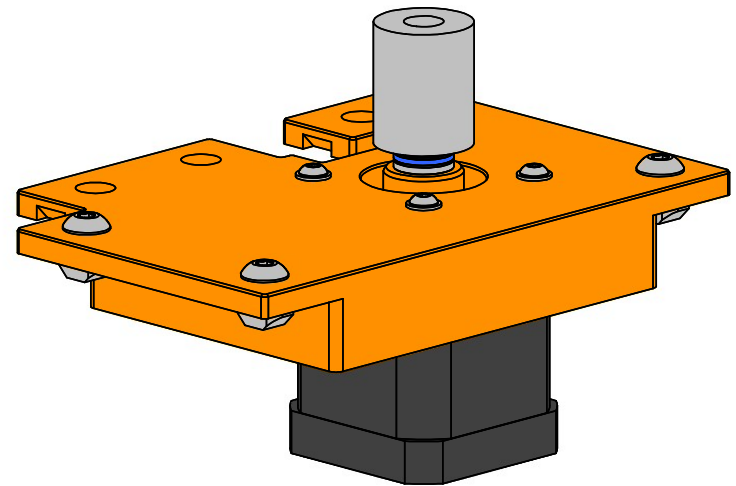

Assembled View

A

ITEM NO.	DESCRIPTION	QTY.
1	M3 Buttonhead Screw, 12mm long	4
5	Z Motor Thrust Coupling Assembly	1
6	M3 Washer	4

Front Left Z Plate Assembly 2



Created by:
Joshua Vasquez

last edited:
6/27/2020

SCALE: 1:1.5

SHEET 8 OF 14

2

1

2

1

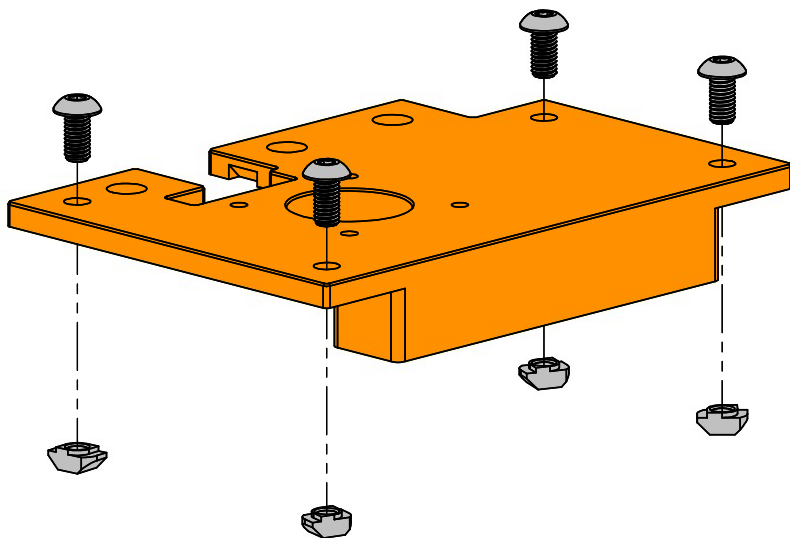

Exploded View

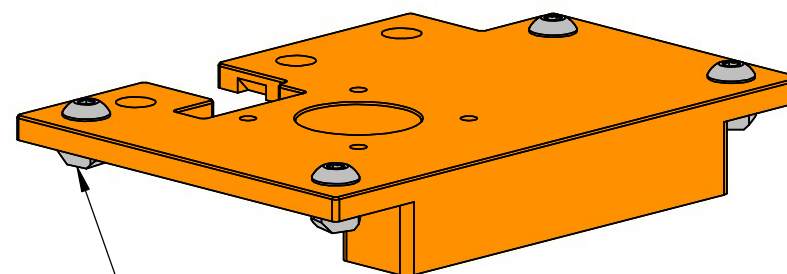

Assembled View

Keep these T-Nuts Loose; only two full turns.
They will be tightened into the frame later.

ITEM NO.	DESCRIPTION	QTY.
1	M5 Buttonhead Screw, 10mm long	4
2	Front Right Z Motor Plate	1
3	M5 Drop-In T-Nut for 20x20 Extrusion	4

Front Right Z Plate Assembly 1



Created by:
Joshua Vasquez

last edited:
6/27/2020

SCALE: 1:1.5

SHEET 9 OF 14

2

1

B

B

A

A

2

1

Apply a dab of threadlock to the four M3 screws before tightening them down securely.

B

B

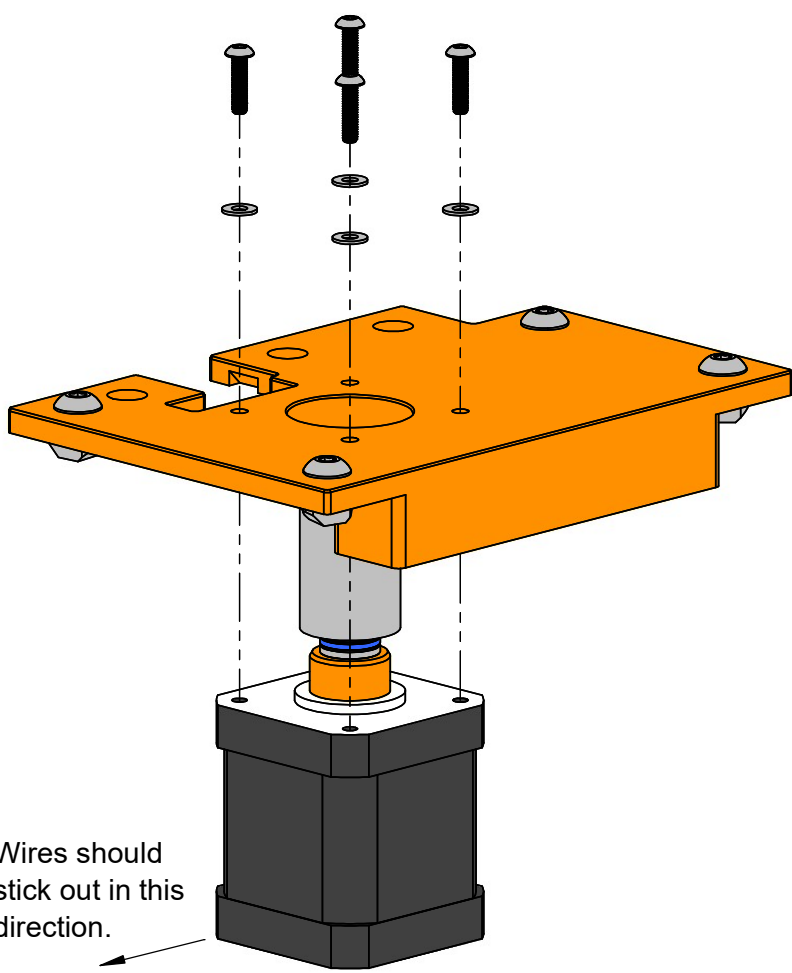

Exploded View

Motor wires should poke up and out from this cavity.

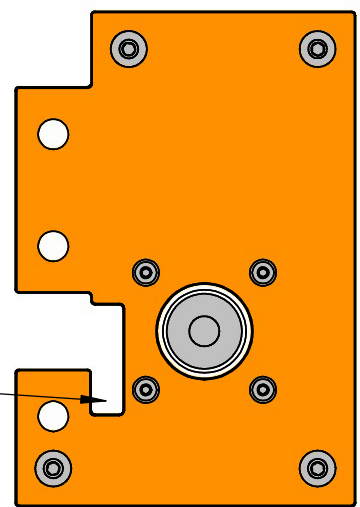

Assembled Top View
Scale 1:2

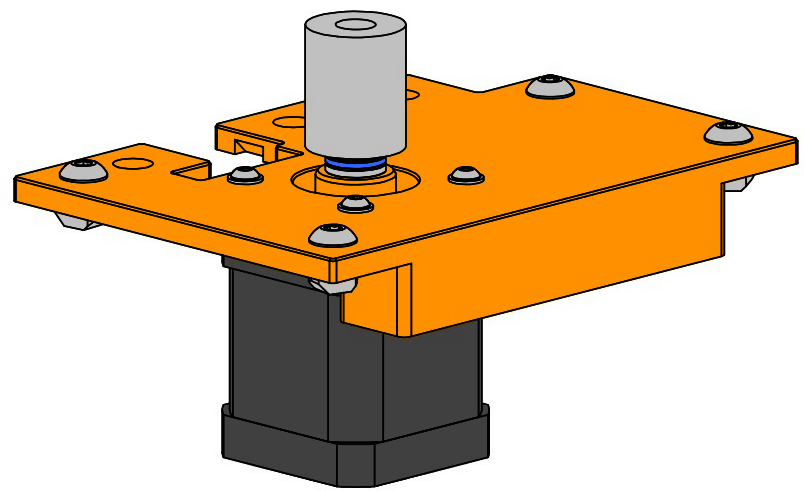

Assembled View

A

A

ITEM NO.	DESCRIPTION	QTY.
1	M3 Buttonhead Screw, 12mm long	4
5	Z Motor Thrust Coupling Assembly	1
6	M3 Washer	4

Front Right Z Plate Assembly 2

	Created by:	last edited:
	Joshua Vasquez	6/27/2020
SCALE: 1:1.5		SHEET 10 OF 14

2

1

2

1

Load the Z Motor Plates into the frame to set the spacing of the internal loose extrusions. Push these internal extrusions into the plates and fully tighten the 8 inside corner brackets shown below.

B

B

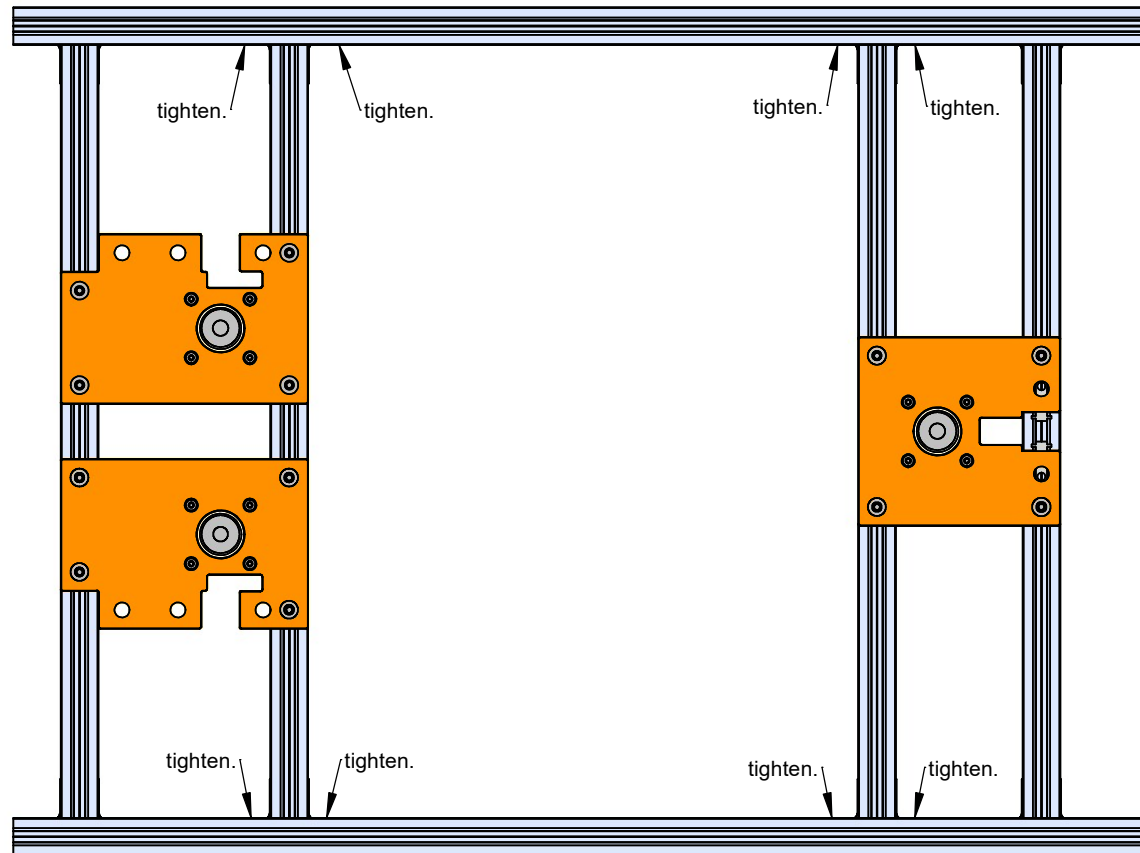

Top View

A

ITEM NO.	DESCRIPTION	
1	Base Frame Assembly with Feet	1
2	Back Z Plate Assembly	1
3	Front Left Z Plate Assembly	1
4	Front Right Z Plate Assembly	1

Internal Extrusion Alignment		
	Created by:	last edited:
	Joshua Vasquez	6/27/2020
SCALE: 1:4	SHEET 11 OF 14	

2

1

A

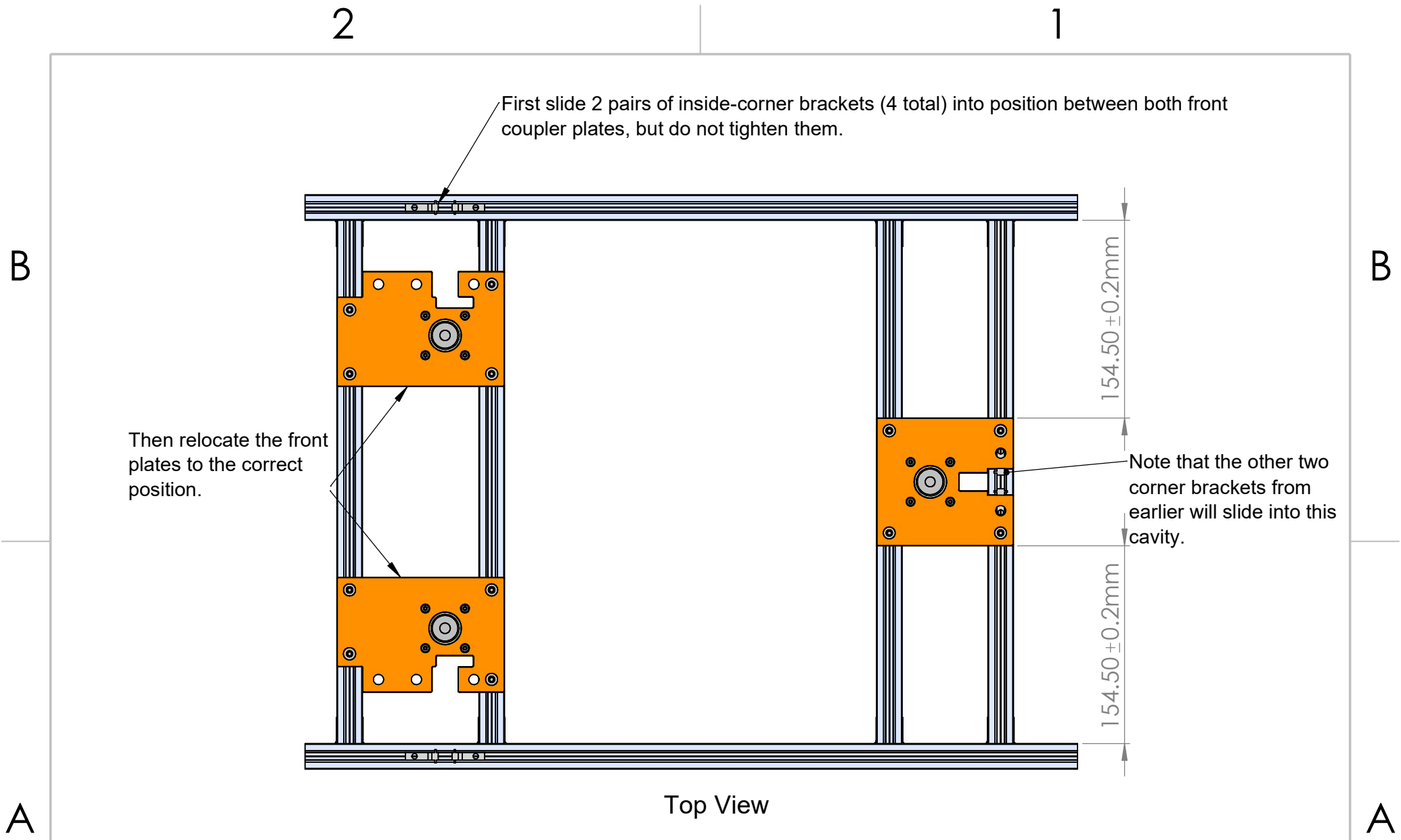

Top View

ITEM NO.	DESCRIPTION	
5	Interior Inside Corner Bracket	4

Z Plate Locating		
	Created by: Joshua Vasquez	last edited: 6/27/2020
	SCALE: 1:4	SHEET 12 OF 14

2

1

Tighten all screws shown below.

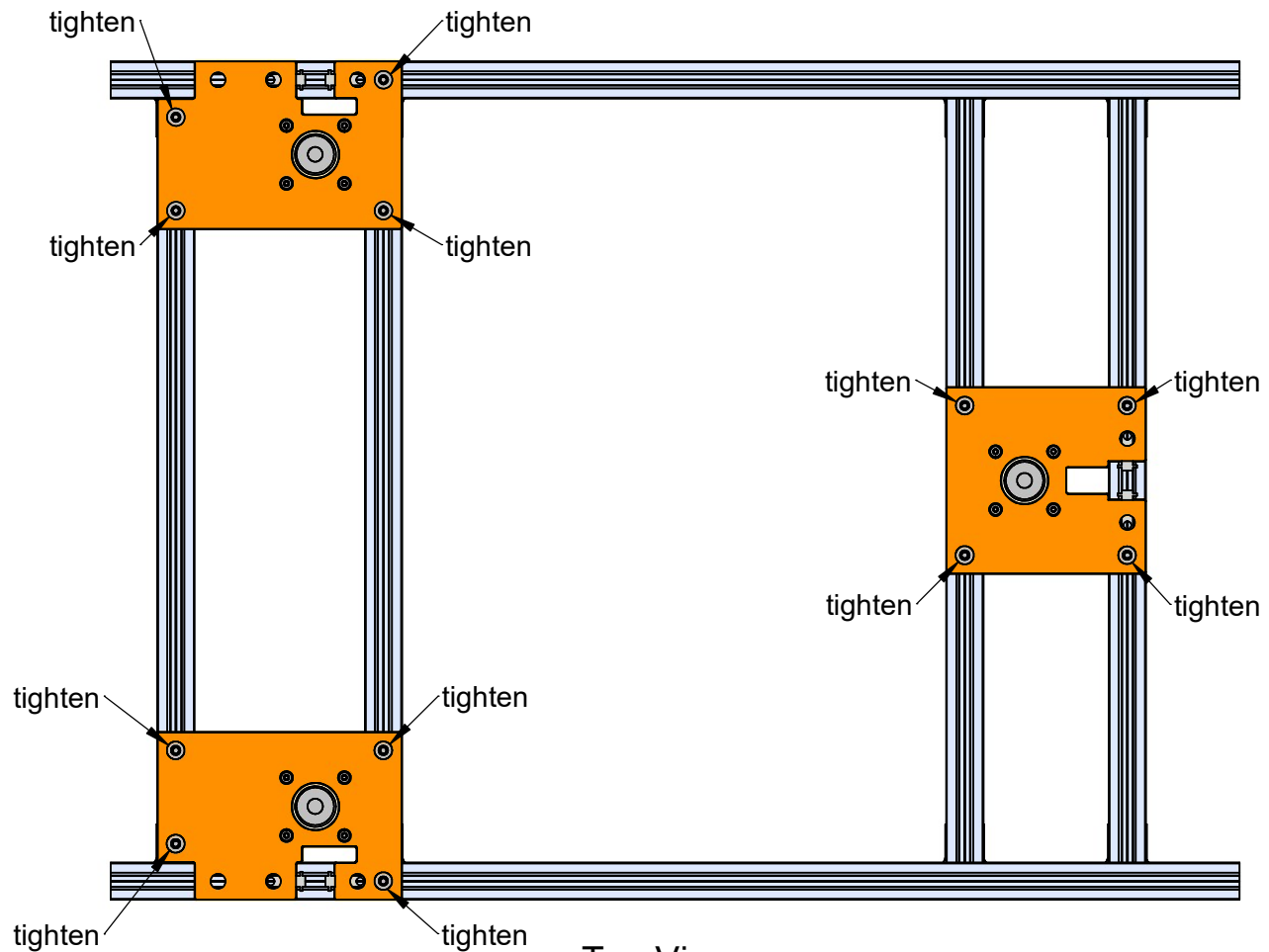

Top View

B

B

A

A

2

1

Z Plate Tightening



Created by:
Joshua Vasquez

last edited:
6/27/2020

SCALE: 1:4

SHEET 13 OF 14

2

1

B

B

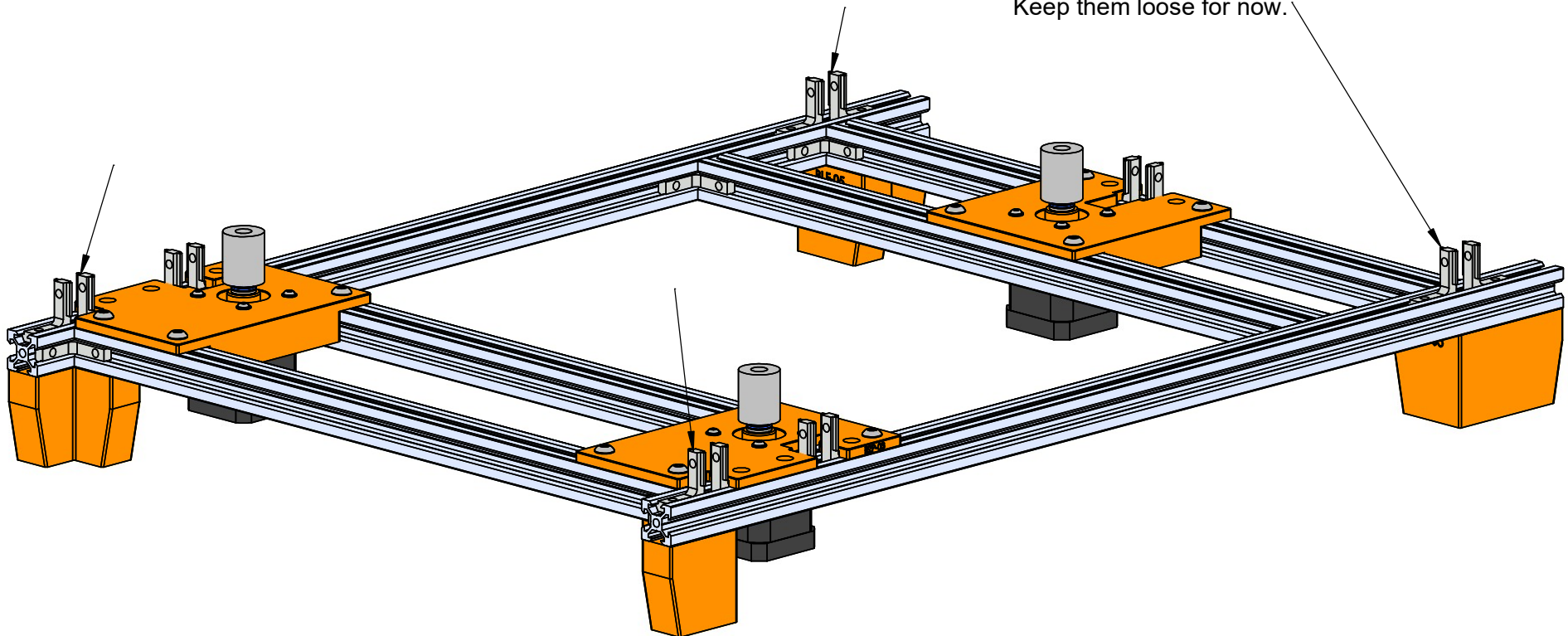

Slide 4 pairs of Inside-Corner Brackets into the approximate locations shown here. Keep them loose for now.

The Lower Frame Assembly is complete!

A

A

ITEM NO.	DESCRIPTION	
5	Interior Inside Corner Bracket	8

Inside Corner Bracket Installation		
	Created by:	last edited:
	Joshua Vasquez	6/27/2020
	SCALE: 1:3	SHEET 14 OF 14

2

1